

DNV

Review of Supervision of SRM controls in OTM Plant:

Report for The Food Standards Agency
report no.: 22325174 v3
5th September 2008

Review of Supervision of SRM Controls in OTM Plant

for

The Food Standards Agency
Aviation House
125 Kingsway
London WC2B 6NH
Client ref: M03064

DET NORSKE VERITAS
Palace House
3 Cathedral Street
SE19DE London
Tel: +44 (0)20 7357 6080
Fax: +44 (0) 20 7716 6730
Registered in England
Company No. 1503799

Report No.: 22325174 v3

Summary: This study has been carried out as part of the policy review of SRM supervision being carried out by the FSA. The SRM Controls model, developed to assess the implications of alternative SRM inspection strategies on the risk of exposure to BSE infectivity, has been extended and applied to OTM slaughter. The report presents the model, assumptions and results representing SRM controls and the inspection regime in place in OTM abattoirs in GB in 2007.

Prepared by: Philip J Comer, Business Leader

Signature

Approved by: Philip J Comer, Business Leader

Signature

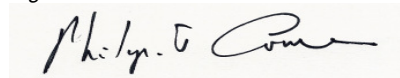

Date of issue: 5th September 2008

Project No: 22325174

- No distribution without permission from the client or responsible organisational unit (however, free distribution for internal use within DNV after 3 years)
- No distribution without permission from the client or responsible organisational unit
- Strictly confidential
- Unrestricted distribution

All copyrights reserved Det Norske Veritas Ltd.. This publication or parts thereof may not be reproduced or transmitted in any form or by any means, including photocopying or recording, without the prior written consent of Det Norske Veritas Ltd..

CONTENTS

1.	INTRODUCTION	1
1.1.	Study Objectives and Approach	1
2.	SRM CONTROLS IN THE UK	2
3.	SLAUGHTER AND PROCESSING OF OTM CATTLE	3
3.1.	Numbers of OTM cattle slaughtered.....	3
3.2.	The Lairage	4
3.3.	Post-Mortem Identification Checks and SRM Removal.....	5
3.4.	Harvesting Head Meat and Tongue Removal.....	6
3.5.	BSE Testing	7
3.6.	Hide removal and evisceration	8
3.7.	Spinal cord	9
3.8.	Final Inspection and Carcase Retention.....	9
3.9.	Storage and Disposal of SRM	9
3.10.	OTM Cutting plant	10
4.	SRM CONTROLS MODEL – OTM CATTLE SLAUGHTER	11
4.1.	The Lairage – Event Tree 1a & 1b	12
4.2.	Post Mortem Inspection – Event Tree 2	14
4.3.	BSE Testing - Event Tree 3.....	14
4.4.	Head Removal and Harvesting the Tongue – Event Trees 4a and 4b	16
4.5.	Spinal Cord Removal and Final Inspection – Event Tree 5	17
4.6.	Test Results and Carcase Dispatch - Event Tree 6.....	18
4.7.	OTM Cutting Plant – Event Tree 7	19
4.8.	Exposure to Infectivity	21
5.	RESULTS	24
5.1.	Base Case	24
5.2.	Sensitivity Assessment.....	26
5.3.	Worst Case Scenario.....	27
6.	CONCLUSIONS	30
7.	REFERENCES	31
	Appendix I - Infectivity of Bovine Tissues.....	33
	Appendix II Assessment of Branch Probability Values in the Expert Workshop	39

1. INTRODUCTION

The Food Standards Agency (FSA) have been carrying out a policy review of the functions performed by the Meat Hygiene Service (MHS) in abattoirs and cutting plants relating to the enforcement of the SRM regulations. As part of this review DNV Consulting have developed an SRM Controls Model that can be used to assess the implications of alternative SRM inspection strategies on the risk of exposure to BSE infectivity. This model was first developed in 2004 and then updated in 2006-2007 to take account of the new EC Hygiene regulations and the harmonisation of UK SRM regulations with those in the rest of the European Community (Review of supervision of SRM controls; DNV Report 22115034, v3; 7 March 2007). This 2007 report also considered cutting plant for over thirty month (OTM) slaughter (but not OTM abattoirs) and sheep slaughter. This present report completes the picture by looking at SRM controls in OTM abattoirs.

This review of the supervision of SRM controls is being carried out against a backdrop of changing risk from BSE in cattle. The levels of supervision were established at a time when the incidence of BSE was very much higher than it is now and it is widely accepted that the risk from BSE to human consumers has reduced considerably.

1.1. Study Objectives and Approach

The objective of this present study is to extend the SRM Controls model to take account of the special features of OTM slaughter and to use the model to assess the potential change in risk exposure for alternative options for enforcing SRM controls in OTM abattoirs.

The study is based mainly on the position in Great Britain (GB) but the general principles should apply UK wide. This study only addresses the role of the MHS in relation to controls applied to Specified Risk Material (SRM), and does not address other areas of their activity, including meat hygiene controls.

The SRM Controls model has been updated for OTM slaughter based on DNV's understanding of OTM slaughter practices as set out in Section 3.0. The updated model has been reviewed with MHS and industry personnel with detailed knowledge of OTM slaughter. This review included the individuals responsible for the implementation of the systems for OTM slaughter in the UK.

The SRM Controls model consists of a set of linked event trees that represent each of the main stages of the slaughter process that may have an impact on exposure to infectivity and is evaluated using a probabilistic risk assessment approach to account for uncertainties in the data. The model incorporates current scientific data on BSE infectivity in cattle and the prevalence of the disease in the UK herd, but also relies on expert judgement to specify values for the various branch probabilities and failure rates defined, for example; *Is the animal ID checked in the lairage?* or; *Would an animal born before August 1996 be identified and removed?* There are no hard data for many of these inputs and for this study they have been estimated using an expert elicitation process in a workshop involving individuals with good knowledge of OTM slaughter processes from both the MHS and industry.

2. SRM CONTROLS IN THE UK

Controls on Specified Risk Material (SRM) were first introduced in the UK in November 1989, then called Specified Bovine Offals. This was about 3 years after the first case of BSE had been identified. Since they were first implemented the rules and list of SRMs have been regularly updated and modified as new information on the disease became available. Similar rules were implemented in the European Union in October 2000.

In May 2006 the SRM rules in the UK were harmonised with those in the rest of Europe as set down in the Community TSE Regulation 999/2001 (as amended). The arrangements for its interpretation and enforcement in England are set out in the Transmissible Spongiform Encephalopathies (No2) Regulations 2006, with similar regulations for Wales, Scotland and Northern Ireland. These regulations were again amended in April 2008, extending the age limit at which vertebral column is classified as SRM from 24 to 30 months.

The Community TSE Regulation defines specified risk material as follows;

Cattle	All ages The tonsils, the intestines, from the duodenum to the rectum, and the mesentery; Over 12 months Skull excluding the mandible but including the brains and eyes, and spinal cord. Over 30 months Vertebral column, excluding the vertebrae of the tail the spinous and transverse processes of the cervical, thoracic and lumbar vertebrae, the median sacral crest and the wings of the sacrum, but including the dorsal root ganglia .
Sheep and goats	All ages The spleen and the ileum Over 12 months (or permanent incisor erupted) Skull including the brains and eyes, tonsils, spinal cord.

In addition:

- if SRM is not removed, the entire carcass of a dead animal, not slaughtered for food, must be treated as SRM. This includes the entire carcass of animals, removed to be rendered or incinerated.
- any material still attached to SRM after dissection of the carcass and any animal matter which comes into contact with that material or with SRM after it has been removed from the carcass will itself be regarded as SRM.

3. SLAUGHTER AND PROCESSING OF OTM CATTLE

Abattoirs vary considerably in many respects, including design, layout, equipment, capacity, and range of species processed. The range of facilities means that there are differences in the precise manner in which the SRM controls are implemented at the plant level. The role of the MHS is therefore to ensure that the requirements of the regulations are met, whilst accommodating the differing work practices and layouts of individual plants. This means that it is impossible to generalise in certain areas, for example on the way identification checks may be carried out. What is presented here is therefore a stylised version of events which is considered to be representative, although it is accepted that there will be differences in the detailed procedures followed by different food business operators (FBOs).

The SRM controls involve more than simply the removal of tissues with the potential to have infectivity from an animal. It is equally important to ensure that the animal arriving for slaughter has been correctly submitted by the farmer and that the animal's age is confirmed by identification checks. Similarly, at the end of the process, controls are required to ensure that the material removed is handled in such a way as to ensure that it cannot re-enter either the human or animal food chain. The following description therefore describes the process at the abattoir from arrival of the animal at the plant to the dispatch of product and disposal of SRM waste.

In September 2005 the Government announced that it had accepted advice from the FSA Board that a reliable BSE testing system had been developed to test cattle that were over thirty months (OTM) old and born on or after 1st August 1996, so that they could once more be allowed to be used for human food. On 7th November 2005 a system of BSE testing for OTM cattle was introduced.

To be able to slaughter OTM cattle for human consumption, abattoirs must be approved by the MHS. In order to be approved plants must first show that they have the necessary pre-requisites, i.e.,:

- Plant and MHS staff trained in handling OTM cattle;
- Staff trained by the VLA in brain stem sampling;
- A Hazard Identification and Control Plan extended to include the risks associated with OTM slaughter;
- Adequate lairage facilities that will allow identification of animals prior to slaughter, and segregation of animals that require testing from those that do not;
- Suitable facilities to allow brain stem sampling to take place;
- A robust traceability system to ensure that the kill number is associated with the sample, the carcass and other body parts;
- Suitable and secure facilities to retain the carcass, body parts, including hide, blood, and by-products under official control, until the test results are received.

Plants handling OTM cattle are required to develop a Recommended Method of Operation (RMOP) to demonstrate that they have robust systems in place which has to be approved by the MHS before the plant can start killing OTM cattle. The plant will also be required to complete a successful 2 day assessment trial, using UTM cattle, to simulate the OTM procedures, which will be monitored by the MHS.

3.1. Numbers of OTM cattle slaughtered

Following the introduction of BSE testing in November 2005, the numbers of OTM cattle slaughtered for food increased steadily as more plants were approved for OTM slaughter from

an initial figure of 8,000 in November 2005 to about 16,500 to 17,000 in the first four months of 2006, and rising to a peak of 48,000 in October. The annual total for 2006 was 333,590. In 2007 the numbers ranged from a peak of 48,000 in January to a low of 15,000 in August, giving an annual total of 404,650, a 20% increase on 2006. This study will be based on the total number of OTM cattle slaughtered in 2007, although there are too few years to know whether or not this will remain a typical figure.

In the first few months there were a significant number of cattle born before August 1996 presented for slaughter at OTM abattoirs, which was a concern for the FSA Board (Paper 08/02/10 to February 2008 meeting of the FSA Board). 325 such cattle have been found at abattoirs in GB from November 2005 to December 2007 and destroyed. There has been good progress in reducing the number of older cattle consigned to abattoirs, with the total in 2007 half that in 2006 despite a 20% increase in the numbers of OTM cattle slaughtered. The numbers continue to fall with the proportion of born before August 96 cattle ranging from .07% to .01% in 2007. As the numbers of these older animals on farm continues to decline this will become less of an issue. For this study the numbers for 2007 will be used. (Pert distribution with maximum of .07%, minimum of .01% and best estimate of .03%).

3.2. The Lairage

The farmer is primarily responsible for presenting animals that meet the required criteria for slaughter, namely that the animal must be:

- In good health and condition;
- Less than thirty months of age for UTM slaughter or born on or after 1st August 1996 for OTM slaughter;
- Identifiable from accompanying passport and ear tag information.

If an animal fails to meet these criteria, it may be refused entry to the abattoir or removed from the system with subsequent loss of income for the farmer. In Scotland the animal may be returned to the farmer, but in England and Wales the animal must remain at the abattoir until the correct documentation has been supplied, and this must be done within 48 hours or the animal will be destroyed and regarded as SRM in its entirety. If an animal older than 30 months is presented for under thirty month (UTM) slaughter in error it may be slaughtered with other OTM cattle if the plant also handles OTM cattle or sent to an OTM slaughterhouse.

Most abattoirs handling OTM animals will also kill UTM cattle. The first step on arrival of animals to the lairage is to check their identification and to separate them into UTM animals, not requiring a BSE test, and OTM animals requiring a BSE test. In addition, any other animals that would require a BSE test (e.g. a casualty animal that is over 24 months) should also be identified, marked and segregated. It is the FBO's responsibility to ensure that animals entering the slaughter process are of the correct age, and have the appropriate documentation, although it would be usual for MHS personnel to observe and/or be involved with these age checks.

The requirements for OTM abattoirs will mean that the identification checks have to be more rigorous than is the case in some UTM plant. Whilst facilities vary between plant, it would be normal for the ear tags of each animal to be checked against the passport as the animals move through a race towards the stunning area. There should be facilities (e.g. a crush) to hold an animal if the tag is difficult to read (e.g. with a metal tag), and the ability to release any

unwanted animal from the race. It would be normal for the sequential kill number to be applied at this stage.

At this time the Official Veterinarian (OV) completes an ante-mortem record form with the FBO or OV completing the first section and the OV noting any signs of BSE. A check of this type is likely to be conducted on a batch of animals, perhaps 25 at a time in a large facility. The OV would then note on the form that he/she was either satisfied with the inspection, or would remove suspect animals to an isolation pen, with the FBO being responsible for any animal handling activities.

There have been a small number of failures with OTM animals slaughtered without a test in UTM abattoirs (6 in GB and 4 in NI). In the main the animals have been only been a few days older than 30 months. These failures have occurred at UTM slaughter. There has only been a single case of an animal born before August 1996 being slaughtered and entering the food supply. This was because the animal had been misidentified on farm.

Although the OV is present in the lairage to inspect animals for signs of disease or distress (including potential signs of clinical BSE), MHS personnel do not normally cross-check identity of passports against ear tag information until post slaughter. The MHS does not conduct identification checks pre-slaughter as this would conflict with 'due diligence', in that they may be seen to approve animals for slaughter that should have been stopped, and would then be potentially responsible in the event of subsequent difficulties.

3.3. Post-Mortem Identification Checks and SRM Removal

Slaughter

The animal is normally stunned using a captive bolt gun. The stunned animal then falls to the floor of the slaughter hall. In some facilities the slaughter man inserts a bung into the stun hole to reduce the potential for release of neural tissue. This has not been common practice in the UK as the whole head was SRM until May 2006. It is not known if this is being done more frequently now that head meat can be harvested or what effect it has on the extent of contamination, but a limited survey of abattoirs suggests that this is still not a common practice. Once stunned, the animal is shackled by one leg, hoisted and suspended above an area to contain the blood. The animal is then slaughtered by cutting the blood vessels in the throat. The blood is collected and can either go for Category 3 waste, if collected in a hygienic manner, or will be sent for rendering and subsequent disposal. For OTM slaughter the blood has to be retained in a secure tank and may only be released once a clear BSE test for the relevant batch has been received.

Identification Checks

Checks by MHS personnel on the identification of cattle are normally carried out post-mortem to avoid the aforementioned due diligence issues. However, in some abattoirs facilities are available where the animal may be restrained in a crush to allow this to take place prior to slaughter, but such sites are in a minority. Although done on all sites for all animals, there is nothing in the law to say that MHS are responsible for PM identification checks. However, the SRM stamp effectively states that the individual MHS inspector is certifying that the meat is free of SRM and suitable for entry into the food chain, and a confirmation of the age and origin of the animal is considered central to any such assurance.

It is essential that a clear and consistent process is adopted by the abattoir in order that any difficulty identified with an animal can be traced to that carcass and all associated tissues before the meat is passed fit. The sequence of animals on the production line therefore needs to be carefully maintained, and this can be confirmed using MHS documentation and other mechanisms (e.g. identification tags).

Once the animal has been stunned and bled, the meat technician checks the ear tag and records the details. The passport may also be reconciled at this point, or this may be done elsewhere outside the slaughter hall. A dentition check is still carried out by MHS staff on OTM carcasses as a physical indication of the likely age of the animal, even though this has no relevance for OTM slaughter.

At this stage the passport becomes the property of the MHS and the Inspector records the number of passports for the day. The passports are then placed in a sealed pouch and returned to the British Cattle Movement Service (BCMS). If an animal's passport is considered dubious, it is marked as not reconciled and returned accompanied by a form which describes the passport, apparent irregularities, and any action required. The entire carcass will then be retained together with any supporting evidence.

It is the role of Trading Standards Officers to follow up and investigate in cases of discrepancies or irregularities, and the farmer's responsibility to provide adequate information to identify the animal. The MHS responsibility is to ensure the animal does not enter the food chain in the event that there are inconsistencies. Although the MHS do not have direct authority to dispose of a carcass, the power to withhold health mark will lead to the carcass being held in the chill for an unlimited time, after which it may not be fit for consumption in any case.

3.4. Harvesting Head Meat and Tongue Removal

As the whole head is no longer SRM head meat can again be harvested subject to certain requirements. The appropriate section of the Community TSE Regulation is given in Box 1 below.

It is now common for head meat to be harvested in UK slaughterhouses. As far as we have been able to determine this is currently all done on line to avoid the requirement for testing for CNS tissue. It is also not usual for the shot hole or *foramen magnum* to be sealed.

In some slaughterhouses, the hide is removed before the head using a hide puller. In this case the complete hide, including the skin of the head, will be removed. The head is removed using two knives to reduce the risk of contamination with spinal cord. The tongue is then removed at a point anterior to the tonsil. However, because the tonsil is a separate tissue, the incision is made at a point in the tongue significantly in front of the area where the majority of tonsil tissue is likely to extend so as to maximise the potential of excluding such tissue. Tongues are inspected by meat inspectors to ensure that they have been removed at the appropriate site. New guidance on tongue removal was issued in 2003 following an experimental result that there could be a low level of infectivity in tonsil tissue. It was considered unlikely that an incorrectly removed tongue would not be detected by MHS personnel. Head meat would not normally be harvested from the same area as the tonsils, so it is unlikely that head meat would be contaminated by tonsil tissue. However, head meat, once harvested, is not batch inspected for the presence of any erroneous tissue, such as tonsil, by MHS staff.

Box 1: Extract from Annex V of the Community TSE Regulations (999/2001) as amended by Commission Regulation (EC) No. 722/2007

- 8.1 Head meat of bovine animals above 12 months of age shall be harvested at slaughterhouses, in accordance with a control system, recognised by the competent authority, to ensure the prevention of possible contamination with central nervous system tissue. The system shall include at least the following provisions:
- harvesting shall take place in a dedicated area, physically separated from other parts of the slaughterline,
 - where the heads are removed from the conveyor or hooks before harvesting the head meat, the frontal shot hole *foramen magnum* shall be sealed with an impermeable and durable stopper. Where the brainstem is sampled for laboratory testing for BSE, the *foramen magnum* shall be sealed immediately after that sampling,
 - head meat shall not be harvested from heads where the eyes are damaged or lost immediately prior to or after slaughter, or which are otherwise damaged in a way which might result in contamination with central nervous system tissue,
 - head meat shall not be harvested from heads which have not been properly sealed in accordance with the second indent,
 - without prejudice to general rules on hygiene, specific working instructions shall be in place to prevent the contamination of head meat during harvesting, in particular in the case where the seal referred to in the second indent is lost or the eyes damaged during the activity,
 - a sampling plan using an appropriate laboratory test to detect central nervous system tissue shall be in place to verify that the measures to reduce contamination are properly implemented.
- 8.2 By way of derogation from the requirements of point 8.1 Member States may decide to apply at the slaughterhouse an alternative system for the harvesting of bovine head meat, leading to an equivalent reduction in the level of contamination of head meat with central nervous system tissue. A sampling plan using an appropriate laboratory test to detect central nervous system tissue shall be in place to verify that the measures to reduce contamination are properly implemented. Member States using this derogation shall inform the Commission and the other Member States in the framework of the Standing Committee of the Food Chain and Animal Health of their control system and the results of the sampling.
- 8.3 If the harvesting is performed without removing the bovine head from the conveyor or hooks, points 8.1 and 8.2 shall not apply.

If the head skin has not already been removed, the head is then flayed (skinned) before other inspection activities are conducted under the Hygiene Regulations (i.e. not SRM Controls) and then the head/cheek meat is harvested if being done.

Once the head has been removed, ear tags can no longer be used to identify individual animals. FBOs have systems to identify animals once heads have been removed based on the 'kill order' on the production line and these will be verified and monitored by the MHS. As animals are on hooks on a continuous conveyor there is no opportunity for the order to change. There were no reports of failures in the carcass tracking systems.

3.5. BSE Testing

BSE testing has to be carried out in a specifically designated location away from the main line, which is often, but not always, a separate room. The FBO is responsible for taking the BSE test sample, and the operator taking the sample must have had the appropriate training. The MHS will supervise the sampling operation. The Veterinary Laboratory Agency (VLA) has provided training for operators who are then able to train other operators at their plant. Defra keep a record of trained personnel. If the sample is not taken properly, so that the correct part of the brain stem is not available for analysis, the laboratory will declare the sample a "no-test", with the result that the carcass will not be allowed into the food chain and have to be destroyed. This will be a major cost to the abattoir so that there is strong motivation to ensure that samples are

correctly taken. The numbers of no tests have fallen steadily from a rate of about 0.1% in 2005 to about 0.02% by the end of 2007 as shown in Figure 3.1.

Figure 3.1: Percentage of BSE Test Samples declared “No Test”

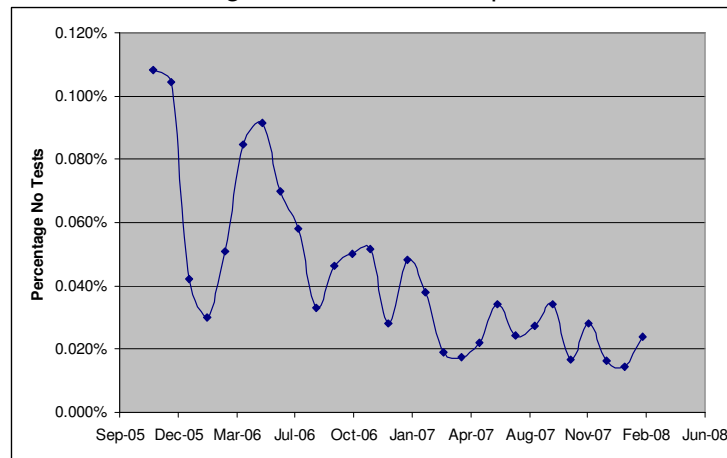

Before the sample is taken the operator will verify the animal identity, either by kill number or ear tag. The sample is taken and placed in a fresh pot, which are now fitted with tamper evident lids, and a printed label with bar code attached to identify the animal. Filled pots are placed in a tray and stored ready for dispatch to the laboratory at the end of the day.

3.6. Hide removal and evisceration

In small abattoirs the carcass is usually flayed in a cradle to remove the hide before being lifted by a winch. In most large abattoirs the carcass will already be suspended and the hide removal will usually be assisted by a hide puller. The puller will do most of the work, but some assistance is usually needed from operators using knives. The carcass is then opened on a platform where the whole gut is removed, and enters the gut room via a chute. All guts, spleen and pluck (lungs, heart and liver for cattle) are inspected, although only the gut is now covered by the SRM controls. All items have to be maintained so as to be identifiable as coming from one animal, and if this is not done in the event of difficulty the entire batch may be condemned. There is therefore a major incentive for the FBO to maintain efficient tracking systems.

All offal has to be tracked and retained as well as the carcass and can only be released into the food supply once a clear BSE test result has been received. Abattoirs have different procedures for dealing with offals which will be set out in the RMOP. Most plant will collect offals into batches rather than track individual parts. In the event of a no test or BSE positive result then the whole batch would be condemned.

Guts are moved to the gut room. Everything beyond the abomasum (stomach) is considered to be SRM. The stomachs may be separated from the intestines and sold as pet food if harvested in an appropriate manner. The intestines from the duodenum to the rectum are classed as SRM and placed in the SRM bin for staining and disposal. Although the staining process is not witnessed on a continual basis, the MHS conduct regular checks of the area and process. There was not considered to be a significant market for intestine in the UK if these were not stained, but a fear was expressed that if a niche existed then there was always a danger it will be filled. In the past intestine would have been used as casings for large sausages and black puddings.

3.7. Spinal cord

The carcass is split using the splitting saw. In large abattoirs the saw will normally be operated from an hydraulic platform. Both band and reciprocating saws are used and will usually be fitted with a water cooling system. As the carcass is split in two the washings are collected and trapped in a 4mm drain trap. The material collected is specified solid waste and is treated as SRM. The operator then removes the spinal cord and cleans the canal using a soft water wash (i.e. low pressure). In some plants a vacuum head is used to finish the cleaning of the spinal canal. The spinal cord is placed in a SRM bin for staining and disposal. There is considered to be no obvious market for spinal cord in the event that it were not stained.

3.8. Final Inspection and Carcase Retention

Once the spinal cord and other SRMs have been removed the carcass is inspected by a MHS meat inspector who checks that the spinal cord has been removed. The examination is specifically looking for residues of spinal cord, as all other SRM tissues would be immediately obvious if present. If spinal cord is found, the procedure is to gather evidence and recommend prosecution.

Following inspection the carcasses are routed to a chill room where they are retained under MHS supervision. When a rail or section is full, the MHS will apply a lock and seal that will be recorded. The carcasses will only be released from retention once a clear set of BSE tests have been received from the laboratory, usually on the morning after the slaughter. The health marks and TSE stamp are then applied at this time.

If there is a no-test then that carcase has to be identified and removed from the line before the remaining carcasses can be released. If there is a BSE positive result then the one before and two after in the line must also be removed and destroyed to minimise the risk of any cross contamination. The carcase handling would be the responsibility of the FBO but would be done under MHS supervision.

3.9. Storage and Disposal of SRM

SRM bins are labelled with "Category 1 High Risk By-Product". Material is transferred from the bins into a skip or similar large container which must also be labelled appropriately. Estimates of the quantity of SRM generated at the plant are recorded. This provides an estimate of weight of tissue which can then theoretically be reconciled to throughput. However, this can be a difficult process as there may also be condemned material, feet, paunch, etc., together with variations due to amount of water in the consignment. This problem is likely to increase in future with the decision to allow mixing of SRM with other categories of material, provided all are treated as SRM.

The responsibility for recording and maintaining a record of SRM weight lies with the FBO, although there are no regular, coordinated cross-checks to ensure what leaves the abattoir is what arrives at the disposal point. SRM material leaves the premises under triple documentation; FBO, haulier, and premises. The OV regularly audits the process of dispatch (potentially monthly inspections on full throughput, 3 monthly in low throughput), but does not inspect each consignment.

Once the SRM leaves the plant it ceases to be the responsibility of the MHS. The destination of the consignment should be known and come from an approved list of premises. It is Defra's responsibility to check records at rendering plants.

3.10. OTM Cutting plant

For OTM animals, the vertebral column may only be removed in approved cutting plant with a specific authorisation to remove OTM bovine vertebral column. The MHS must be informed that such animals are coming to the plant, and a MHS presence will be arranged for the duration of the process. Once the results from the BSE tests have been received at the abattoir, provided there are no positives or no tests, the carcasses are stamped by the MHS and they may be moved to a cutting plant. If the cutting plant is remote, the loading is supervised by the MHS and the container sealed. The container may only be opened with MHS supervision at the cutting plant.

The basic operation of the cutting plant is not changed between UTM and OTM operations, except that the VC removed in the OTM operation must be placed in a SRM bin, stained and disposed of as SRM. When a cutting plant is handling UTM material there is no requirement for full time supervision and the plant will only be inspected on a risk basis.

4. SRM CONTROLS MODEL – OTM CATTLE SLAUGHTER

The SRM Controls Model has been developed as a set of linked Event Trees in an Excel spreadsheet using Precision Tree¹. The model has been designed to estimate the amount of BSE infective material, in terms of Bovine Oral ID₅₀ units, that may enter the food chain for a defined set of SRM controls. The previous version of the model was set up for the situation for UTM abattoirs in the UK in 2006. This has now been reviewed and extended to cover the processes in abattoirs handling OTM cattle. Data have been selected to reflect the situation in the UK in 2007. The model can be used to assess the impact of alternative SRM control enforcement strategies.

The model is evaluated using @RISK¹, a commercial probabilistic risk assessment tool that works as an add-in to Excel. The model is run many times, and for each model run (or iteration) the combinations for each varying parameter are selected at random. These values are chosen from specific probability distributions that have been defined for that parameter. The number of model runs are high enough to ensure that all possible combinations of parameters have eventually been selected a sufficient number of times to allow an evaluation of the probability of occurrence of the corresponding risks. For the results reported here, the model has been run using Latin Hypercube sampling and 10,000 iterations. Latin Hypercube sampling is a stratified sampling technique that ensures the full range of the input distribution is sampled without the need for excessive iterations.

There are two sets of input data for the model. The first data set concerns BSE infectivity for the various SRM tissues and the prevalence of BSE in the UK herd. The background and assumptions for BSE infectivity and prevalence are derived from the previous TSE risk assessment work carried out for the FSA and are set out in Appendix I. The second set relates to the branch probabilities that concern SRM removal and the enforcement of SRM controls. In general there is little or no data to establish these probability values and it is necessary to rely on expert judgement. For this study the branch probability values have been established using a mini Delphi expert elicitation method in an Expert Workshop. The workshop was attended by representatives of both the Meat Hygiene Service and industry who had knowledge of slaughterhouse operations, a consumer representative and representatives from both Defra and the FSA. Details of the workshop approach and results are given in Appendix II.

The overall slaughter process has been divided into a number of stages so that all the activities that can affect the possible risk of exposure to infectivity are covered. It was found that the process can be represented in nine stages and each of these is modelled as an event tree. The nine event trees that make up the model are:

- 1a: Cattle Identification in Lairage;
- 1b: Ante-mortem inspection in Lairage;
- 2: Post mortem inspection;
- 3: BSE Testing;
- 4a: Harvesting the tongue;
- 4b: Harvesting Head meat;
- 5: Spinal cord removal and final inspection;
- 6: BSE Test results and carcass dispatch
- 7: OTM Cutting Plant

¹ Precision Tree and @RISK are Decision analysis and Risk analysis tools developed by the Palisade Corporation of 31 Decker Road, Newfield, NY 14867, USA. www.palisade-europe.com

The individual Event Trees and the branch nodes are described in Sections 4.1 to 4.7. With each Event Tree there is a table giving the data for the branch probabilities resulting from the expert elicitation workshop and the calculated probabilities of each branch outcome.

Two sets of values are shown on each event tree figure. Firstly, the branch probabilities at each branch are given. The values shown on the figures are the **calculated mean values** for the defined distribution. These will be different from the “Best Estimate” values given in the accompanying tables. Thus in Figure 4.1, Event Tree for Lairage, the value given on the “No” branch at the first node, “ID checked in Lairage”, is 1.7E-04 (0.00017). This is the mean value for the distribution given in Table 4.1 with a best estimate (or expected value) of 1.0E-05 (1:100,000) and a range from 1:1,000,000 to 1:1000. The second set of values is the overall probabilities for the complete branch and these are found at the end of the branch. Thus in Figure 4.1, the value given for the same branch is 1.7E-04, which is the same as the branch probability for the single branch. For the top branch in the figure the overall branch probability given is 0.9975; this is the product of the two decision points that make up that branch (0.9998 and 0.998).

In many event trees, two or more branches will have the same outcome. For example, in Event Tree 1, the second and third branches both result in animals born before August 1996 not being identified and going to slaughter. In these cases the outcome probabilities are combined to give a single outcome in the “Branch Outcome” table. The values given in these tables are the calculated mean values.

4.1. The Lairage – Event Tree 1a & 1b

There are two important activities that should happen in the lairage before the cattle are slaughtered; the first is an ante-mortem check carried out by the Official Veterinarian and the second is an identity check. These two activities are considered in event trees 1a and 1b. The FBO is required to check the identification of animals presented for slaughter to ensure that all have the correct documentation and that none were born before August 1996. In OTM plants this is done systematically with each animal being individually checked against their passport.

The purpose of the ante-mortem inspection is to identify any animals that are not fit for human consumption or are injured in any way. A particular requirement is to identify any animals with signs of BSE. Casualty animals have been shown to have a higher prevalence of BSE than normal healthy stock so it is important to identify any high risk animals.

In addition, it is assumed that 0.1% of animals entering the lairage are “high risk” and should be identified at ante mortem inspection. There is no central collection of data on the numbers of animals rejected at ante mortem inspection.

The two event trees are similar, each with two decision points, and the values chosen are shown in Table 4.1. In most cases the branches are defined by specifying maximum, minimum and best estimate values.

The values determined by the Expert Workshop indicate that the chances of an animal born before August 1996 or a high risk animal getting past the lairage inspection and entering the slaughter process is small (less than 1%).

Figure 4.1: Event Trees 1a & 1b– Identification and Health Check in Lairage

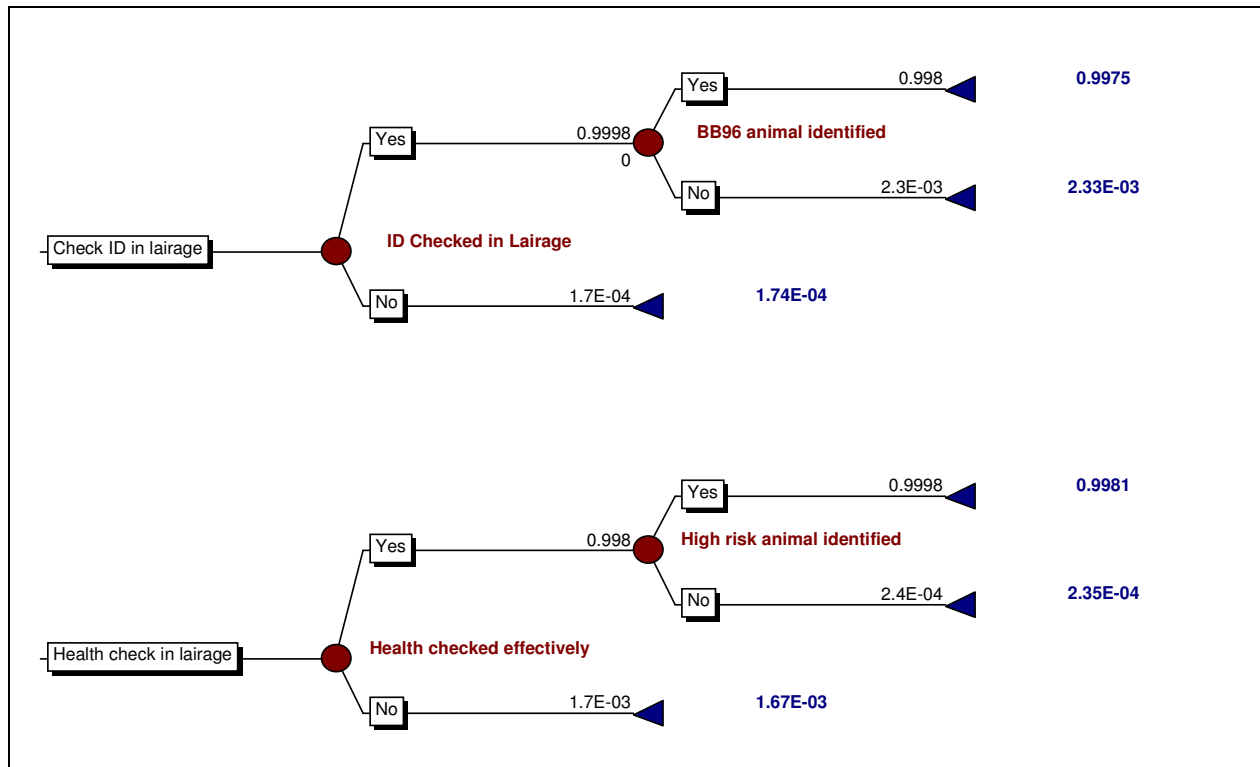

Table 4.1: Branch Probabilities and Outcomes for Event Trees 1 & 2

Branch Description	Probability Values		
	Minimum	Best Estimate	Maximum
Animal identification NOT checked in lairage	1:1,000,000	1:100,000	1:1000
BB96 animal NOT identified (if checked)	1:100,000	1:1000	1:100
Health NOT checked effectively	1:1,000,000	1:100,000	1:100
High risk animal NOT identified	1:100,000	1:10,000	1:1000

Branch Outcomes	Outcome Probability
BB96 animals identified and removed	0.9975
BB96 animals go to slaughter	2.51E-03
High risk animal identified	0.9981
High risk animal go to slaughter	1.91E-03

4.2. Post Mortem Inspection – Event Tree 2

With the current controls it is most unlikely that an animal born before August 1996 would not be identified post slaughter by the passport identification check. This is reflected in the branch probabilities given in Table 4.2. With the assumptions determined by the expert workshop it is estimated that only about 0.04% of any animals born before August 1996 not identified in the lairage would enter the human food supply.

Figure 4.2: Event Tree 2 – Post Mortem Inspection

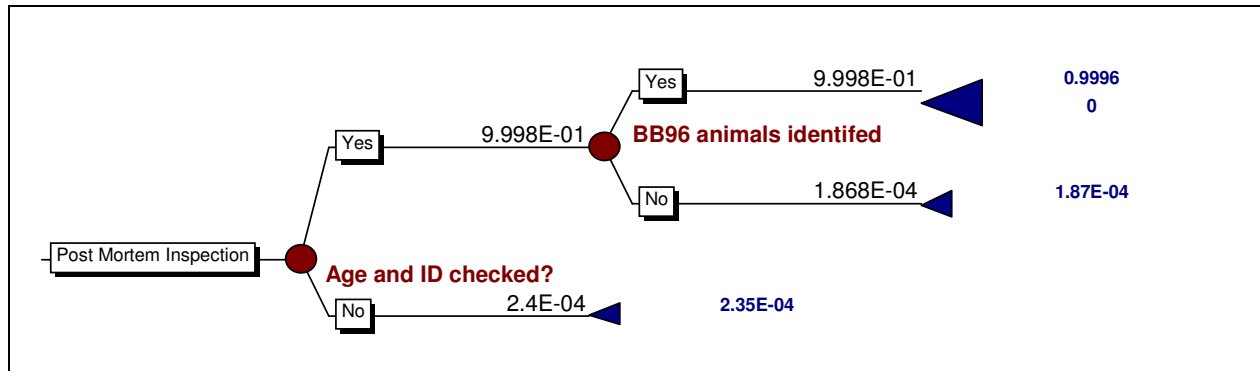

Table 4.2: Branch Probabilities and Outcomes for Event Tree 2

Branch Description	Probability Values		
	Minimum	Best Estimate	Maximum
Animal identification NOT checked Post Mortem	1:100,000	1:10,000	1:1000
BB96 animal NOT identified	1:1,000,000	1:33,300	1:1000

Branch Outcomes	Outcome Probability
BB96 animal enters process	4.2E-04

4.3. BSE Testing - Event Tree 3

A brain stem sample is taken from each head, normally after the head has been removed from the carcass. The head would normally be labelled and identity retained through the kill sequence. The FBO is responsible for all handling, taking the sample and placing it in a pot and labelling. The MHS supervise and monitor this activity.

Failures include the possibility that a sample could be substituted, e.g. in the event that the operator is aware that the sample taken is not satisfactory and would result in a no test, and mislabelling of a sample.

The outcome for this tree is a sampling error, such that a test result may be associated with the wrong carcass.

Figure 4.3: Event Tree 3 – BSE Testing

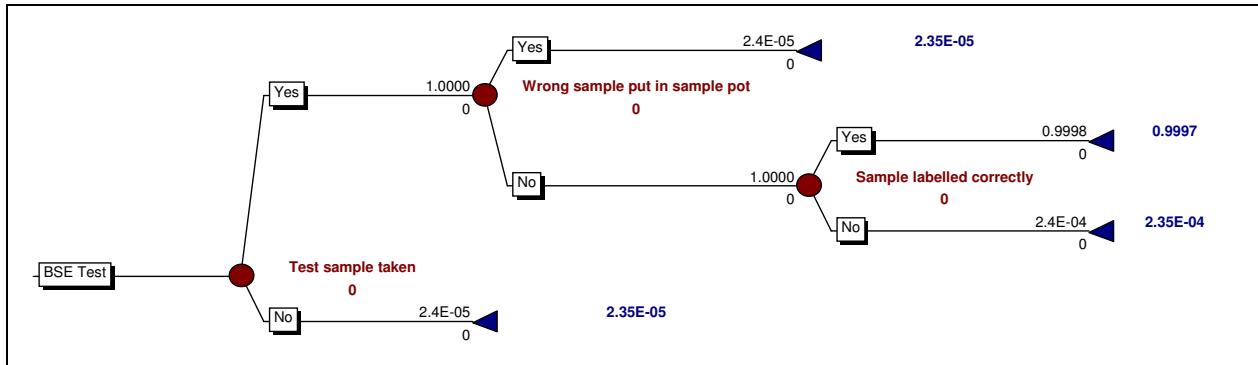

Table 4.3: Branch Probabilities and Outcomes for Event Tree 3

Branch Description	Probability Values		
	Minimum	Best Estimate	Maximum
Brain stem sample not taken	1:1,000,000	1:100,000	1:10,000
Sample substituted	1:1,000,000	1:100,000	1:10,000
Sample not correctly labelled	1:100,000	1:10,000	1:1000

Branch Outcomes	Outcome Probability
Sampling error	2.8E-04
Carcass correctly sampled	0.9997

4.4. Head Removal and Harvesting the Tongue – Event Trees 4a and 4b

A survey of the operators of OTM abattoirs was undertaken with members of the British Meat Processors Association and the Association of Independent Meat Suppliers. In total the FBOs that responded represented about 40% of the total OTM slaughter. The results showed that all FBOs harvested tongue, and that most (95%) of the larger abattoirs harvested head meat and about 50% of the medium sized plant. It was estimated that overall head meat is harvested from 75% of the OTM animals slaughtered. Very few FBOs reported using bungs to seal the frontal shot hole or the Foramen Magnum.

The event tree for Tongue is very simple and reflects the fact that it is the FBO's responsibility to remove the tongue which is then inspected by the MHS. The data indicate that the tongue will be cut correctly most of the time, and that it is unlikely that an incorrectly trimmed tongue would be missed by the inspection. With the selected input data, the model estimates that the chance of an incorrectly trimmed tongue entering the food supply is 4×10^{-7} per year.

With few FBOs using a seal on the shot hole or *foramen magnum*, it was considered likely, in discussions with the MHS, that there could be some level of contamination from CNS tissue on all heads. The amount of contamination is discussed in Section 4.8.

Figure 4.4: Event Tree 4a – Harvesting the Tongue

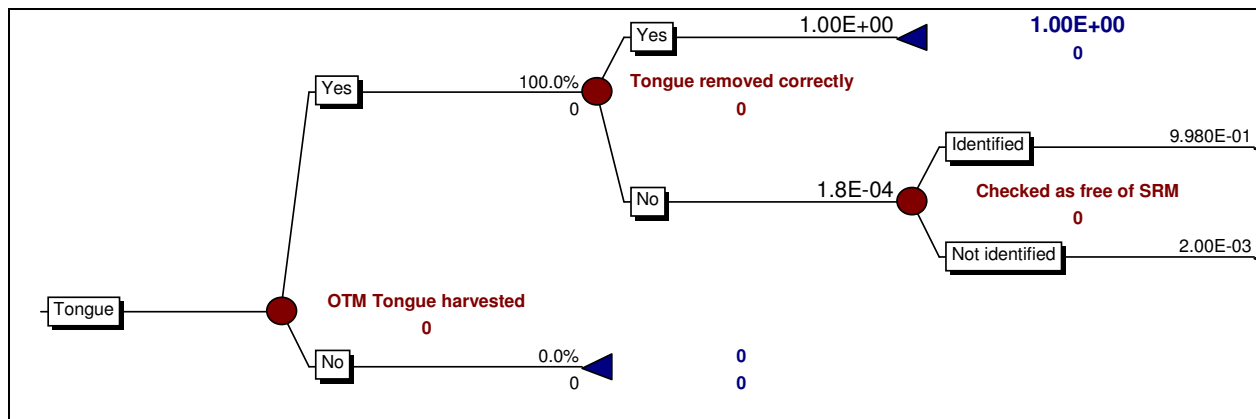

Figure 4.5: Event Tree 4b – Harvesting Head Meat

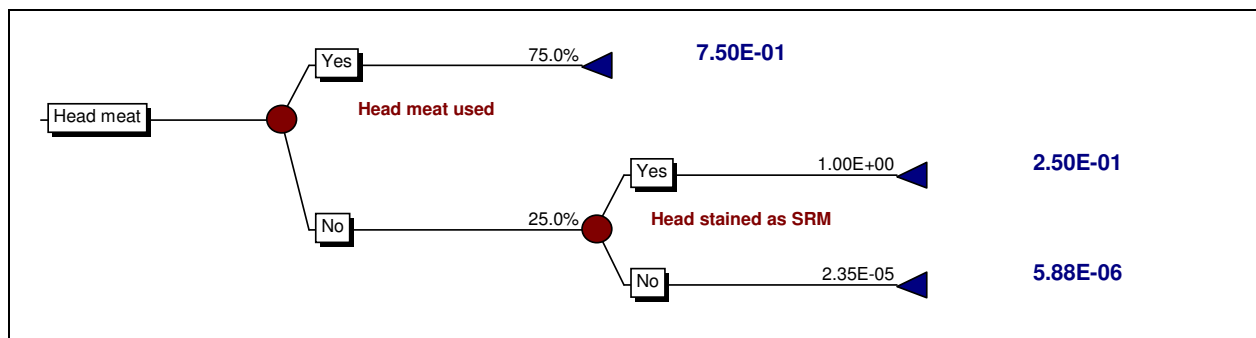

Table 4.4: Branch Probabilities and Outcomes for Event Trees 4 a & b

Branch Description	Probability Values		
	Minimum	Best Estimate	Maximum
OTM Tongue harvested		1.0	
Tongue not removed correctly	1:100,000	1:50,000	1:1000
Inspection fails to identify incorrectly trimmed tongue	1:100,000	1:2000	1:100
Head meat harvested in abattoir		0.75	
Head not stained as SRM	1:1,000,000	1:100,000	1:10,000

Branch Outcomes	Outcome Probability
Tongue with SRM into food supply	3.6 E-07
Head meat into food supply	.75

4.5. Spinal Cord Removal and Final Inspection – Event Tree 5

This Event Tree reflects the fact that it is the FBO’s responsibility to remove the SRM material and that this is then inspected by the MHS. It is considered unlikely that any spinal cord would be left on a carcass (best estimate 1 in 33,000) and extremely unlikely that any residual SRM would not be identified by the inspection. The expected number of OTM carcasses being passed with any spinal cord remaining is estimated to be 4×10^{-4} per year (e.g. 9×10^{-10} x the number of OTM animals slaughtered – 405,000).

Figure 4.6: Event Tree 5 – Removal of the Spinal Cord

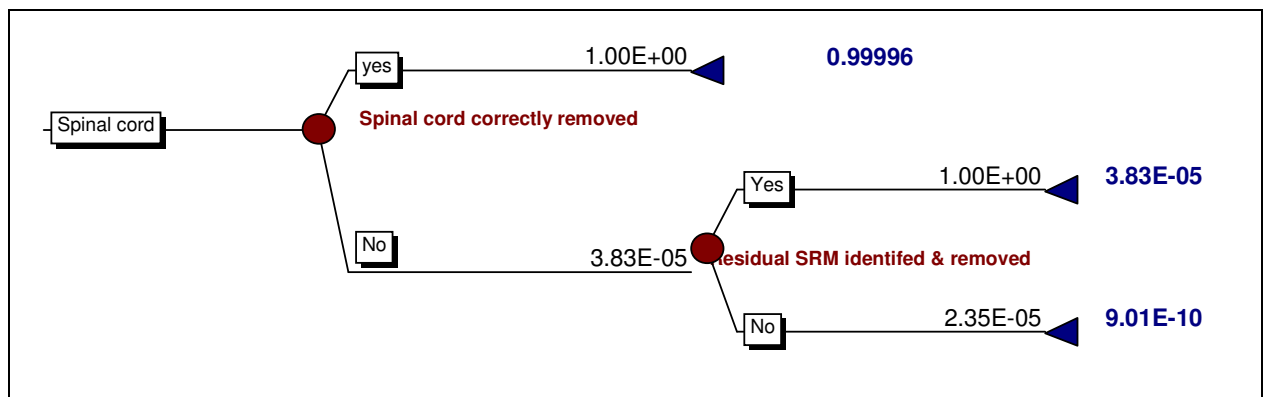

Table 4.5: Branch Probabilities and Outcomes for Event Tree 5

Branch Description	Probability Values		
	Minimum	Best Estimate	Maximum
Parts of spinal cord left on carcass	1:100,000	1:33,300	1:10,000
Residual SRM not identified at final MHS inspection	1:1,000,000	1:100,000	1:10,000

Branch Outcomes	Outcome probability
Carcass with some spinal cord remaining	9.0 E-10

4.6. Test Results and Carcass Dispatch - Event Tree 6

All carcasses have to be retained in a sealed cold store under MHS control, until a clear set of test results are received. Any carcass with a “No Test” must be removed and treated as SRM. If there are any positive test results then that carcass, together with the one before and two after (1B2A), are removed and treated as SRM. The remaining clear carcasses are then health marked by the MHS and sent on for further processing.

As indicated in Section 3.5, the rate of no tests has fallen from the start of OTM testing, to a rate of about 200 per million slaughtered, averaging 280 per million over 2007. This rate for 2007 will be used in this assessment. There have only been a total of 6 BSE positives since the start of OTM testing, with 3 in 2006 and 3 in 2007. The rate of BSE positives was 7.4 per million in 2007, and this will be used in this assessment. The group at the expert workshop felt that it was very unlikely that a no test or BSE positive carcass would not be removed and destroyed as there were a number of independent checks to ensure that this would happen.

Figure 4.7: Event Tree 6 – Test Results and Carcass Dispatch

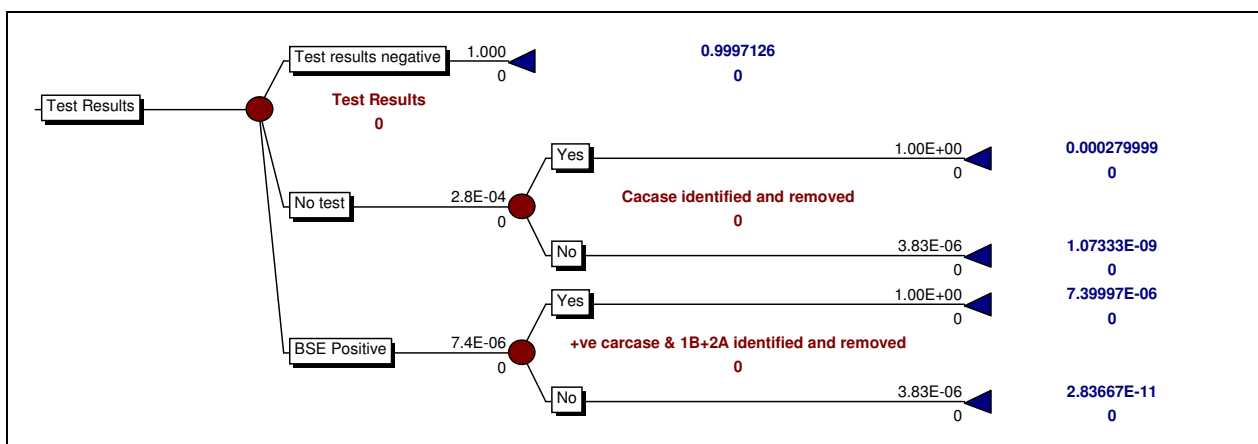

Table 4.6: Branch Probabilities and Outcomes for Event Tree 6

Branch Description	Probability Values		
	Minimum	Best Estimate	Maximum
One or more result is a "No Test"		2.8 x 10 ⁻⁴	
BSE Positive result received		7.4 x 10 ⁻⁶	
No Test carcass not identified and removed	1:1,000,000	1:333,000	1:100,000
BSE positive and 1B2A not identified and removed	1:1,000,000	1:333,000	1:100,000

Branch Outcomes	Outcome probability
No Test carcass enters food supply	1.1 E-09
BSE positive carcass enters food supply	2.8 E-11

4.7. OTM Cutting Plant – Event Tree 7

The event tree for the OTM cutting plant operation is shown as Figure 4.8. This attempts to represent whether the carcasses are properly identified as being OTM, whether the vertebral column is removed correctly and then whether the VC is disposed of as SRM. With the present level of inspection it is considered unlikely that OTM carcasses would not be sent to an approved cutting plant or not be properly identified on arrival.

The majority of approved cutting plant use the sheet boning method as this is much more efficient. The Expert Workshop suggested that less than 1% would use traditional boning (where 7% of DRG is left on the bone rather than 0.5% - see section 4.8.6) and that this would also cover the possibility of additional DRG being left on the meat. If the OTM carcass is not sent to an approved cutting plant, it is assumed to be processed as a UTM carcass where a proportion might be sold on the bone.

Table 4.7: Branch Probabilities for Event Tree 7

Branch Description	Probability Values		
	Minimum	Best Estimate	Maximum
OTM carcass not sent to approved cutting plant	1:1,000,000	1:333,000	1:100,000
OTM meat sold bone-in (estimated as for UTM)		1:87	
OTM carcass not identified in cutting plant so processed as UTM	1:1,000,000	1:100,000	1:100,000
Proportion of cutting plant using traditional boning or excess DRG left on meat	1:1000	1:100	1:20
VC not disposed as SRM	1:1,000,000	1:100,000	1:10,000
VC used in human food	1:1,000,000	1:1,000,000	1:100,000

The vertebral column (VC) removed from OTM carcasses is disposed of as SRM, and this is supervised and verified by the MHS. If the VC were not disposed of as SRM, this could be an error (e.g. placed in the same bin as for UTM, non SRM, bones) or because of an attempt to divert the material to another outlet. Even in this event, the Expert Workshop found that it was extremely unlikely that the material would enter the human food supply.

Table 4.8: Branch Outcomes for Event Tree 7

Branch Outcomes	Outcome probability
Removal of SRM	
VC removed correctly	9.85E-01
Additional DRG left on meat	1.5 E-02
Carcase processed as UTM	8.5 E-06
Carcase processed in non approved cutting plant	3.8 E-06
SRM Disposal	
VC disposed as SRM	1.00E+00
VC not disposed as SRM	3.2 E-05
VC used in food	5.8 E-11

Figure 4.8: Event Tree 7 – OTM Cutting Plant Operation

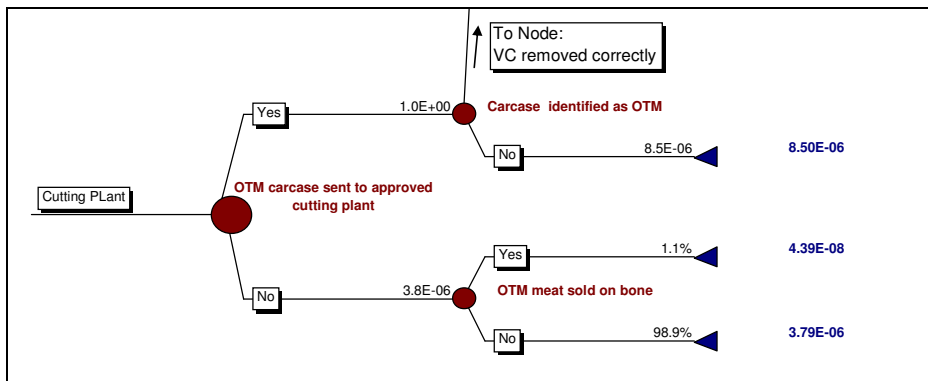
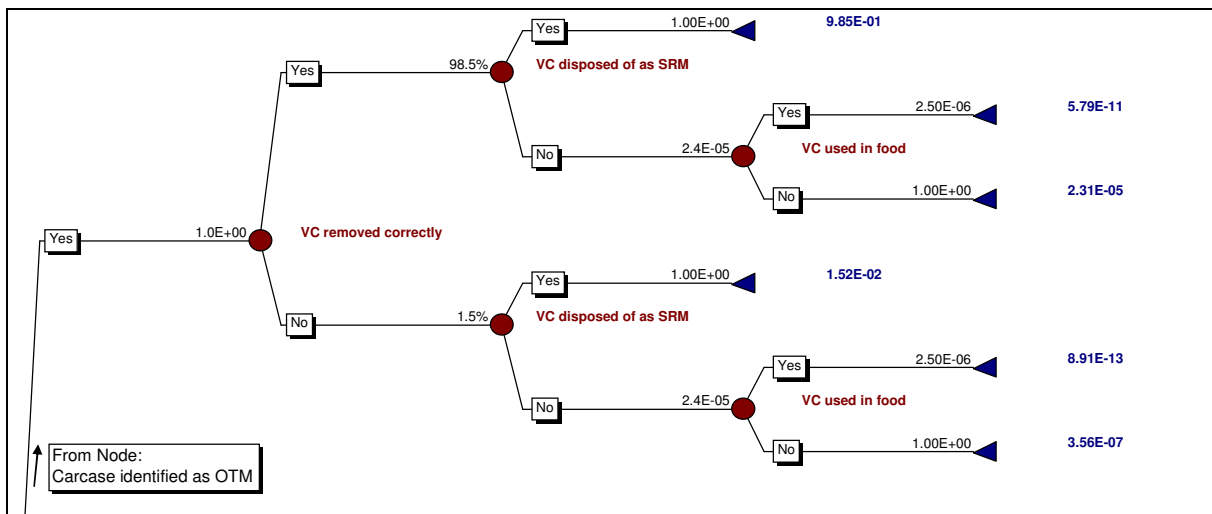

4.8. Exposure to Infectivity

The final stage in the model is to estimate the potential exposure to infectivity. The event tree model provides estimates of the likelihood that SRM tissues may get into the food chain (e.g. spinal cord left on carcass) and the probability that a carcass is derived from an animal born before August 1996 or a high risk animal. These are then combined with estimates of infectivity for each of the tissues and the likelihood that an animal is infected with BSE. The infectivity estimates are based on those used for the risk assessment carried out for the review of the Over Thirty Month rule (Comer and Huntly, 2004) updated by other studies, such as DNV reports on bovine tongue and beef-on-the-bone (DNV, 2003 & 2005) and any new scientific data. The new data includes estimates for the infectivity in peripheral nervous system tissues, following a number of recent reports of very low levels of infectivity found in some peripheral nervous system tissues using highly BSE sensitive mice (Buschmann & Groschup, 2005; Iwata et al, 2006).

The data used for the infectivity and prevalence estimates are presented in full in Appendix I, with the key results summarised below.

4.8.1 Infectivity of Bovine tissues

The infectivity profile used takes account of the most recent results from the attack rate experiments carried out by the VLA.

The infectivity titre in the brain of a clinically BSE infected bovine is assumed to follow the following distribution:

Log normal distribution with

Median (50 percentile): 5 cattle oral ID₅₀/gram

Higher 99 percentile: 100 cattle oral ID₅₀ (CoID₅₀)/gram

It is assumed that infectivity increases over the incubation period with a 2 month doubling time.

The relative infectivity in different tissues are assumed to be as before, with the infectivity in DRG assumed to be as for brain and the infectivity in tonsil 5 orders of magnitude less. The values used are given in Table I.1.

4.8.2 Prevalence of BSE Infection

Estimates of the proportion of cattle that were slaughtered with BSE infection in 2007 have been provided by the VLA using the back-calculation model of Arnold and Wilesmith (2003) for three age groups:

1. Cattle born before 1 August 1996
2. Cattle born on or after 1 August 1996 that are over 30 months of age
3. Cattle under 30 months of age.

The estimates are given in Table I.2 for both before and after BSE testing where this is appropriate, and for three time periods: less than 3 months before onset, 4 to 6 months before onset and 7 to 12 months before onset. The last column in Table I.2 gives a weighted mean value, where the proportion with infection is weighted by the infection level for the incubation stage assuming a 2 month doubling time.

4.8.3 Exposure from Tongue

There is a possibility of exposure to infective material if tonsil tissue is left on the tongue. The potential level of infectivity in tonsil tissue is very low, and the model indicates that most tongues would be cut correctly. However, as noted by SEAC (2003) and also by EFSA (2008), even when cut correctly there may still be some lingual tonsil tissue remaining as there are large variations in the distribution of the tonsil tissue on the tongue (Wells et al, 2005). For this study, it is assumed that if the tongue is not cut correctly that 10% of the lingual tonsil tissue would remain on the tongue. This is the same as in the risk assessment presented to SEAC (DNV, 2003) and the previous version of the SRM controls model, and would be about 5g of tissue, which is likely to be a precautionary estimate. In this version of the model it is now also assumed that if cut correctly there may still be some lingual tonsil tissue present, but a factor of 10 less than on an incorrectly trimmed tongue.

4.8.4 Exposure from Spinal Cord

The inspection regime means that the likelihood of any spinal cord being left on a carcass is very low. If there is a failure it is assumed that 5% of the spinal cord (i.e. 10g) is left on the carcass. It is then assumed, as a worst case scenario, that this material would be consumed. In reality, as most meat is cut from the bone, it is likely that the major part of any contamination would in fact be disposed of and not enter the human food supply.

There will also be some contamination on a carcass from spinal cord due to the fact that the carcass is split with a saw through the vertebral column so that some spinal cord tissue will be spread over the cut surface. In studies to measure the extent of this contamination Knight (2001) reported between 50 and 100 mg of CNS tissue on each cut surface. These values will be used as a uniform distribution. This contamination was included in the risk assessment for the OTM review where, in discussion with the FSA's Risk Assessment Group which acted as an expert review group for the study, it was decided to include a factor of 1% for the amount of this contamination that would be transferred to meat and so consumed (Comer and Huntly 2004). This recognised that the cut surfaces are mainly bone and that the majority of carcasses are deboned before sale to the final consumer. This factor is also included in this assessment.

4.8.5 Exposure from Head Meat

As indicated in section 4.3, it was considered likely that there would be some level of contamination from CNS tissue on all heads. There is at present no data on the extent of possible contamination, although it is understood that there is now a study underway to determine this. EC rules require that a sample of the head meat harvested is tested for the presence of CNS tissue, unless the head meat is harvested with the head still on the hook or conveyor at the slaughterhouse. It is our understanding that at present all head meat is being harvested in this way, so that there has been no CNS testing in GB.

In previous studies, the estimates from Cooper and Bird (2002) have been used. They studied slaughterhouse procedures and estimated the amount of CNS contamination per head as 1.28g (95% range 0.35 – 2.93). This study was based on the practices current at that time, which included transport of heads to specialist head boning operations, and would not reflect the current requirements and controls. This is therefore felt to be a high estimate for the current practice, and a distribution has been adopted with a median value a factor of 10 less and a 99 percentile of 1.28g. This is then applied to all heads from which the head meat is harvested. In the sensitivity assessment (see Section 5.2)

4.8.6 Exposure from Dorsal Root Ganglia (DRG)

The exposure from dorsal root ganglia (DRG) has been estimated taking account of the data on alternative boning practices that was reported and used in DNV (2005). This showed that with sheet boning only 0.5% of the DRG would be left with the meat, whilst with traditional boning about 7% of DRG may be left in the meat.

For OTM cattle all carcasses have to be boned in approved cutting plant specifically authorised to remove bovine vertebral column and the vertebral column disposed of as SRM. There is no data on the proportion of approved cutting plant that use sheet boning, but at the Expert Workshop it was estimated that this would be the case for 99% or more. The proportion using traditional boning is taken to include the possibility of cutting plant failures such that more DRG is left on the meat. The chance that carcasses may not be sent to an approved cutting plant is included in the model. In this situation meat may be sold on the bone (assumed to be the same frequency as for under 30 month animals) and it is assumed that the boning is done using the traditional method.

5. RESULTS

5.1. Base Case

The SRM Controls Model has been run for the slaughter of OTM cattle in Great Britain for the conditions and regulations pertaining to 2007. The overall numbers of OTM animals slaughtered and the estimated numbers of those born before August 1996 and sent to slaughter are shown in Table 5.1.

The estimated quantities of BSE infectivity entering the human food supply due to failures in SRM controls and infectivity present in meat are presented in Table 5.2. The table shows the total infectivity from all animals slaughtered and the contributions from the various sources of infectivity (e.g. DRG, spinal cord, head meat and tongue). The values presented are the mean and median values from the probabilistic risk simulation plus the 2.5 and 97.5 percentiles of the distribution. The values represent the amount of BSE infectivity in terms of bovine oral ID₅₀ units that could enter the food supply with the current average annual slaughter of 405,000 over thirty month old cattle. The 2.5 and 97.5 percentiles represent the effective range of the results given the uncertainty in the input parameters

Table 5.1: Case Definition Parameters

Number of OTM Cattle slaughtered (per year)	405,000
Proportion of these born before August 96	0.03%
Proportion of these high risk	0.1%
BB96 animals slaughtered	0.3
BB96 animals to process	1.4E-04
High risk animal slaughtered	0.77

Table 5.1: Estimated Infectivity into the Food Supply from OTM Slaughter

Estimated Infectivity into Food Supply					%
	Mean	Median	P2.5	P97.5	
Bovine oral ID ₅₀ /yr					
Dorsal Root Ganglia in meat	3.3E-01	1.4E-01	1.1E-02	1.9E+00	33.6%
Tongue with SRM into food chain	8.8E-06	3.8E-06	3.1E-07	4.8E-05	0.00%
Head meat used in food	4.0E-01	9.6E-02	3.6E-03	2.5E+00	41.0%
CNS on carcass due to splitting	2.7E-03	1.1E-03	8.8E-05	1.5E-02	0.27%
Carcass with some spinal cord remaining	1.6E-08	4.9E-09	2.1E-10	1.0E-07	0.00%
PNS Tissue	2.4E-01	2.3E-02	2.8E-04	1.9E+00	25.16%
Total Infectivity into Food Supply	9.9E-01	3.5E-01	2.4E-02	5.7E+00	

The total estimated infectivity into the food supply from OTM slaughter in GB in 2007 is estimated to be a median value of 0.35 bovine oral ID₅₀ units (95 percentile range: 0.02 to 5.7). The overall distribution of the total infectivity into the food supply is shown in Figure 5.1.

Figure 5.1: Estimated Total Infectivity into Food Supply from OTM Slaughter

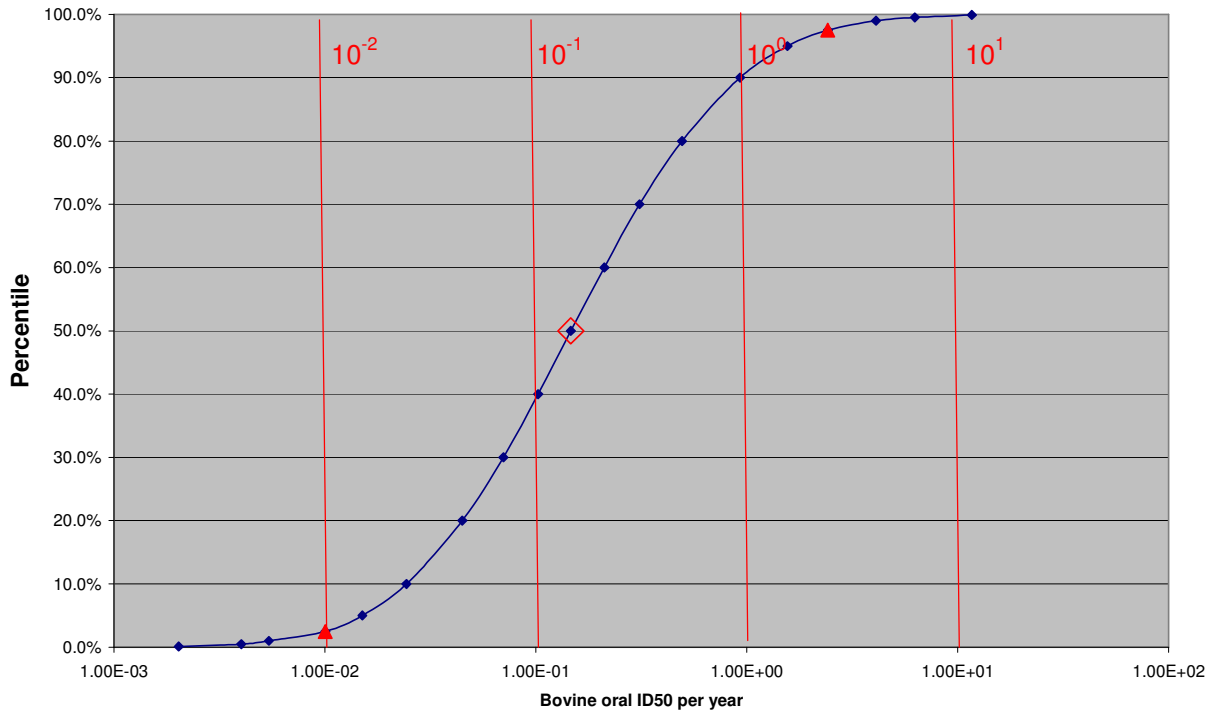

There are three main contributors to the total infectivity as shown in Table 5.2; DRG in meat (34%), contamination on head meat (41%) and infectivity in peripheral nervous system tissues (25%). The contribution from SRMs entering the food supply due to failures in SRM controls is estimated to be extremely small (e.g., 2×10^{-8} bovine oral ID₅₀ units for spinal cord left on a carcass). There is a small contribution from high risk animals not identified at ante mortem inspection (0.02%) and also a small contribution from untested or no-test animals entering the food supply (0.13%). In both cases these contributions are negligible compared to the background contribution from residual infectivity in meat from DRG and PNS and the potential contamination of head meat.

In order to interpret the estimated exposure for risk to people it is necessary to take account of the cattle to human species barrier. The size of the species barrier is not known, but, as set out in Appendix I Section I.6, there are indications that it is a factor of about 4000. Taking account of a species barrier, 0.35 bovine oral ID₅₀ units spread over the entire beef eating population of the United Kingdom would represent an extremely low level of risk.

5.2. Sensitivity Assessment

The sensitivity to some of the individual assumptions made in the assessment has been investigated. The model has been re-run with alternative assumptions as described below and the results presented in Table 5.3.

Head Meat Contamination: CNS contamination of head meat is assumed to be at the maximum value of 1.28g per head rather than a distribution where this represents the 99 percentile value. This will increase the exposure from head meat by a factor of 10, and increasing the overall infectivity into the food supply by 250% from a median value of 0.35 BoID₅₀/year to 1.2 BoID₅₀/year.

Infectivity in DRG: In this study it has been assumed that the infectivity in the DRG is the same as that in the brain. A reanalysis of data from the pathogenesis experiment by Mark Arnold at the VLA has indicated that infectivity in the DRG may be less than that in the CNS by a factor of up to 1000 depending on the incubation stage. The impact of reducing the infectivity in the DRG by a uniform range of values between 0 and 3 logs has been investigated. With this assumption, the overall exposure estimate is reduced by 40% from 0.35 BoID₅₀/year to 0.20 BoID₅₀/year with head meat contributing 58% of the total and DRG 7%.

Combination of maximum head meat contamination and lower DRG infectivity: Combining the previous two assumptions results in just over a 200% increase in the overall infectivity into the food supply giving a median value of 1.1 BoID₅₀/year. The contribution from head meat contamination is now 89% and that from DRG only 2%.

Doubling Time: As indicated in Appendix I, Section I.2, it has been suggested that the doubling time should be a mean value of 1.3 rather than the value of 2 used in this assessment. This would result in a reduction in the estimated infectivity into the food supply of about 60%, giving a median value of 0.15 BoID₅₀/year.

Table 5.3: Summary of Sensitivity Assessment

Sensitivity Scenario	Median exposure BO ID ₅₀ /yr	Change from base	Head meat contribution	DRG contribution
Base Case	0.35		41.0%	33.6%
Head meat contamination at max value (1.28g)	1.23	255.2%	80.1%	11.3%
Lower infectivity in DRG	0.20	41.3%	57.6%	6.7%
Combine 1 & 2	1.10	218.5%	88.7%	1.8%
Doubling time 1.3 months	0.15	57.6%	41.0%	33.6%

5.3. Worst Case Scenario

In the previous sections the exposure has been estimated as an expected value, taking account of the likelihood that an infectious animal is slaughtered, the probability of failures in the SRM controls and the amount of infectious material. It is also interesting to consider a worst case scenario, such as a BSE positive animal that is either not tested but enters the food supply or an animal with a BSE positive test result that is not removed (e.g. due to misidentification). The question then is how much infectivity would enter the food supply and what difference would the SRM controls make to the exposure.

The likelihood of a BSE positive animal being slaughtered and entering the food supply is very low. The prevalence of BSE cases in OTM animals is estimated to be 1.1×10^{-6} (see Appendix I, Table I.2), i.e., about one in a million. The chance that an animal with a BSE positive test result was not identified correctly (along with the one before and two after) and removed was estimated at the Expert Workshop to be between $1:10^6$ and $1:10^5$. This makes the overall probability of a BSE positive case entering the food supply vanishingly small at less than $1:10^{10}$.

Table 5.4: Infectivity into food supply from one maximally infected carcass

a) Exposure from DRG

Estimated Infectivity into Food Supply Bovine oral ID50 per infected carcass				
	Mean	Median	P2.5	P97.5
1. All sirloin and rib sold on bone	89	35	2	515
2. Boned using sheet boning method	2	0.7	0.1	10
3. Boned with traditional boning	25	10	1	144

b) Exposure from Complete Carcass

Estimated Infectivity into Food Supply Bovine oral ID50 per infected carcass				
	Mean	Median	P2.5	P97.5
Weighted mean from DRG	2.11	0.89	6.9E-02	12.19
Tongue with SRM into food chain	5.7E-05	2.5E-05	2.0E-06	3.1E-04
Head meat used in food	2.48	0.63	2.5E-02	15.48
CNS on carcass due to splitting	1.7E-02	7.3E-03	5.7E-04	9.7E-02
Carcass with some spinal cord remaining	1.0E-07	3.2E-08	1.4E-09	6.6E-07
PNS Tissue	1.58	0.15	1.8E-03	12.58
Total Infectivity into Food Supply	6.19	2.24	1.6E-01	35.76

The estimated exposure from an infected carcass entering the food supply will depend on how the carcass is butchered and whether or not head meat is harvested. All OTM carcasses should be butchered in an approved cutting plant where the vertebral column will be removed and treated as SRM. In the unlikely event that meat from an OTM carcass was sold on the bone, then the potential exposure from DRG could be much greater. This is shown in Table 6.4 (a). The results show that the maximum exposure would occur if the beef from the rib and sirloin was all sold with the vertebral column attached, with the remainder of the carcass butchered using traditional methods. In this case the median exposure is estimated to be 35 bovine oral ID₅₀ per carcass with a 97.5 percentile value of 515. However, as already noted, it is highly unlikely that an OTM carcass would be processed in this way. The majority of carcasses are processed in cutting plants using sheet boning and the median exposure for this is estimated to be 0.7 bovine oral ID₅₀ per carcass.

The total estimated exposure from an infected carcass entering the food supply is then shown in Table 6.4 (b). This has the same assumptions as for the base case, except that it is assumed that all the head meat is used and an average of the exposure from DRG weighted by the likelihood of each method including the possibility that it would be sold on the bone. It is estimated that one infected carcass entering the food supply would result in a mean total exposure of 6.2 bovine oral ID₅₀ with a median value of 2.2 and a 95 percent range from 0.2 to 36 bovine oral ID₅₀. The exposure is dominated by the contributions from DRG, head meat and PNS. It is very unlikely that any one person (or family) would consume all the meat and thus all the infectivity from one carcass as it would normally be sold as cuts or joints to many people, unless it was for example used by a farmer for home consumption.

The infectivity estimated to enter the food supply from a fully infected animal is only a small fraction (about 0.1%) of the total infectivity present (see Table I.1 in Appendix I). It is not considered credible that the brain or a major part of the spinal cord would enter the food supply. Thus the SRM controls eliminate more than 99% of the infectivity present.

5.4. Changes to SRM Controls

One of the options being considered by the FSA in their review of the supervision of SRM controls is to reduce the amount of supervision and checking done by the MHS on animal identity. For OTM slaughter, the main reason for checking identity is to ensure that no animals born before August 1996 enter the food supply. Older animals being presented for slaughter were a problem when OTM animals were first allowed back into the food supply in November 2005 but the proportion of born before August 96 cattle presented for slaughter has reduced to between 0.01% and .07% in 2007 (see section 3.1). These numbers will continue to fall naturally as the numbers of these older animals on farm decline.

There are two stages of identity checks carried out. The first is prior to slaughter as the animal is moved from the lairage to the stunning pen. This is the responsibility of the FBO, but would normally be supervised by the MHS. A second check is then carried out post mortem, and this second check is usually done by MHS staff. At the Expert workshop, the likelihood of an animal identity not being checked and an animal born before August 1996 not being identified before slaughter was considered to be extremely small. Similarly the expert workshop also considered it extremely unlikely that an animal's identity would not be properly checked post mortem.

In 2007, a total of 107 BB96 animals were presented for slaughter at OTM abattoirs, with the numbers ranging from 3 to 17 per month. With the present level of ante mortem identification checks, it is estimated that a mean of 0.3 animals per year (i.e., about one in three years) would be missed and slaughtered.

Using the model it is possible to test the impact on the risk of exposure to BSE infectivity as a result of making changes to the way in which the cattle identification checks are carried out. A series of four options have been evaluated and the results presented in Table 5.5 together with the base case for comparison. The four options are:

1. The post-mortem inspection is 100 times less effective than for the base case;
2. No post-mortem identity checks are carried out;
3. No post-mortem identity checks are carried out and 10% of cattle miss the ante-mortem inspection;
4. No ante-mortem or post-mortem identity checks carried out.

The latter option is included to show what would happen if there were no identity checks carried out, not as a serious option for consideration.

The results in Table 5.5 show that changes to the post-mortem inspection will make little or no difference to the potential infectivity that could enter the food supply. Thus, whilst the number of BB96 animals entering the food supply increases from 0.0001 per year with the present inspection regime up to 0.3 per year with no post-mortem inspection, the total infectivity into the food supply does not increase significantly as the contribution from BB96 animals is still small (the total number of BB96 animals is small, prevalence is higher than for OTM animals but still low and all SRM materials are removed). Even if the effectiveness of the ante-mortem inspection is also reduced, so that 10% of animals are not checked, the contribution from BB96 animals remains low (0.35%) and there is still no significant increase in the infectivity entering the food supply. The upper limit is represented by modelling the effect of assuming that there were no identity checks. In this case, there are now 135 BB96 animals slaughtered and entering the food supply, and these contribute 3.4% of the total infectivity.

Table 5.5: Effect of Changes to Cattle Identification Checks

	Number of BB96 animals to process/yr	Infectivity into food supply Bovine oral ID ₅₀ /yr		
		Mean	P97.5	Proportion due to BB96
0. Base Case	1.4 x 10 ⁻⁴	0.99	5.7	.000004%
1. Post-mortem check 100 times less effective	1.4 x 10 ⁻²	0.99	5.7	.0004%
2. No post-mortem identity check	0.34	0.99	5.7	0.009%
3. 10% of animals miss ante-mortem inspection – no post-mortem inspection	14	0.99	5.7	.36%
4. No ante-mortem or post-mortem identity checks	135	1.02	5.9	3.4%

6. CONCLUSIONS

The SRM Controls model, originally developed in 2004, has been updated to account for changes in SRM controls, abattoir practices and new scientific data and extended to account for the special features of OTM slaughter. In this study the model has been applied to the slaughter of OTM cattle in GB. The main conclusions from the study are:

- The amount of BSE infectivity entering the food supply from slaughter of over thirty month old cattle with the current SRM control regime is extremely small, about 0.35 bovine oral ID₅₀ unit per year (range 0.02 to 6) for the whole GB population. Taking account of the cattle to human species barrier this represents an extremely low level of risk.
- The main contributors to the exposure are contamination of head meat (41%), DRG in the meat (34%) and infectivity in PNS (25%).
- The exposure to infectivity as a result of failures in the SRM controls (e.g. spinal cord left on a carcass) is shown to be extremely small.
- There is a small contribution from untested or no-test animals entering the food supply, estimated to be 0.13% of the total.
- In the unlikely event that a BSE positive animal was to be slaughtered and not identified, then it is estimated that the total infectivity entering the food supply would be a median value of 2 bovine oral ID₅₀ units (range 0.2 to 36). More than 99% of the total infectivity present would be removed by SRM controls.
- The model has been used to assess the effect of changes to the supervision of animal identity checks. The results show that changes to post mortem identity checks will make little or no difference to the infectivity that may enter the food supply.
- These results demonstrate that the risk of exposure to BSE infectivity is now very low and the SRM controls are robust. Given that most of the predicted exposure is inherent in the way cattle are slaughtered and butchered (e.g., infectivity in DRG; PNS etc), changes to the supervision of SRM Controls are unlikely to result in any significant increase in exposure risk.

7. REFERENCES

References for both Main Report and Appendix I

- Arnold, M., and Wilesmith, J.W. (2003). Modelling studies on bovine spongiform encephalopathy occurrence to assist in the review of the over thirty months rule in Great Britain. *Proc. R. Soc. Lond. B*, **270**, 2141-2145.
- Buschmann, A and Groschup, M. H (2005) Highly Bovine Spongiform Encephalopathy-Sensitive Transgenic Mice Confirm the Essential Restriction of Infectivity to the Nervous System in Clinically Diseased Cattle. *The Journal of Infectious Diseases*, 192, 5, 934-942
- CJD Surveillance Unit (2005), Creutzfeldt-Jacob Disease Surveillance in the UK. Fourteenth Annual Report, 2005. www.cjd.ed.ac.uk/report14.pdf
- Clarke, P. and Ghani, A.C. (2004). *Projections of the future course of the primary vCJD epidemic in the UK: inclusion of subclinical infection and the possibility of wider genetic susceptibility*. *J.R.Soc. Interface* (doi:10.1098/rsif.2004.0017)
- Comer, P.J. and Huntly, P.J. (2004) Exposure of the human population to BSE infectivity over the course of the BSE epidemic in Great Britain and the impact of changes to the Over Thirty Month Rule. *Journal of Risk Research*, **7** (5), 523-543.
- Cooper, J.D. and Bird, S.M. (2002) UK dietary exposure to BSE in head meat: by birth-cohort and gender. *J. of Cancer Epidemiology and Prevention*, **7**, No. 2, 71-83.
- DNV (2003). Assessment of BSE risk from bovine tonsil (DNV Report, 20071300, 21st May 2003).
- DNV (2005). Assessment of risk from under 30 month beef-on-the-bone (DNV Report, 22308490, 22nd April 2005).
- DNV (2006). OTM Rule Replacement: Independent Review of BSE Testing System (DNV Report, 22312319-02, 3rd July 2006).
- EFSA (2005), Quantitative assessment of the residual BSE risk in bovine derived products; EFSA QRA Report, 2004 - Working Document. *The EFSA Journal* (2005), 307, 1-135.
- EFSA (2008). Consumption of beef tongue: Human BSE risk associated with exposure to lymphoid tissue in bovine tongue in consideration of new research findings. *The EFSA Journal* (2008), 700, 1-24.
- Iwata, N. et al (2006) Distribution of PrP^{Sc} in Cattle with Bovine Spongiform Encephalopathy Slaughtered at Abattoirs in Japan. *Japan J. Infectious Diseases*, 59, 100-107
- Knight, A. C. (2001) Dispersion of CNS Material during splitting of cattle and sheep carcasses. In *Food Standards Agency TSE Research Seminar Report*, Loughborough University, 22-23 November 2001.
- LFRA (1997) *Audit of Bovine and Ovine Slaughter and By-products Sector* MAFF Project No. SE0217, by Leatherhead Food Research Association and the Meat and Livestock Commission.
- SEAC (2003) DNV Risk assessment report on ox tongue and associated tonsil tissue. Paper No. SEAC 78/2. www.seac.gov.uk/papers/seac78_2.pdf
- SSC (2000) EC, Scientific Steering Committee, *Opinion: Oral Exposure to Humans of the BSE Agent: Infective Dose and Species Barrier* Adopted by the SSC at its meeting on the 13th - 14th April 2000.
- Wells, G. A. H., Spiropoulos, J., Hawkins, S. A. C., and Ryder, S. J. (2005) Pathogenesis of experimental bovine spongiform encephalopathy: preclinical infectivity in tonsil and observations on the distribution of lingual tonsil in slaughtered cattle *The Veterinary Record*, 156, 13, 401-407.
- Wells, G.A.H., Konold, T., Arnold, M.E., Austin, A.R., Hawkins, S.A.C., Stack, M., Simmons, M.M., Lee, Y.H., Gavier-Widén, D., Dawson, M., and Wilesmith, J.W. (2007). Bovine spongiform encephalopathy: the effect of oral exposure on attack rate and incubation period in cattle. *Journal of General Virology*, 88, 1363-1373.

Appendix I - Infectivity of Bovine Tissues

A key input to the risk assessment is the amount of infectivity present in the material to which people may be exposed. There are four factors that need to be assessed in order to determine the potential infectivity of any bovine tissue to humans:

1. The infectivity of central nervous system (CNS) tissues from an animal with clinical BSE to another bovine
2. The relative infectivity of non-CNS tissues in an animal with BSE;
3. The development of infectivity through the incubation period of the disease; and
4. The cattle-human species barrier.

I.1 Infectivity of CNS tissues from an animal with BSE

The Veterinary Laboratory Agency (VLA) in the UK has carried out experiments to identify the effect on cattle of oral doses of BSE infected cattle brain. In this “attack rate” experiment groups of 10 calves were each fed 300g, 100g, 10g and 1g of an homogenate made from the brain stems from clinically sick animals. All animals in the two higher dose categories came down with BSE, and 7 out of 10 in both the 10 g and 1g trials. The range of incubation periods for both the 1g and 10g trials were similar (44 – 71 months). An extension of the attack rate experiment has recently been completed with doses of 1g 100mg, 10mg and 1mg (Wells *et al*, 2007). The results show 3 of 5 in the 1g trial group, 7 out of 15 animals in the 100mg group, 1 out of 15 in the 10mg group, and 1 out of 15 in the 1mg group, positive for BSE. Incubation periods for the positive results in both the 1 and 10mg groups were similar to those for the 1 g trial, but two of the animals in the 100mg group had incubation periods in excess of 90 months.

Wells *et al* (2007) report that the ID₅₀ estimate from these experiments is equivalent to 0.20 g of the brain homogenate used (i.e. 5 ID₅₀/g) with a 95% confidence interval of 0.04 – 1.00g. Interim results from these experiments were considered by an EFSA working group in preparing a quantitative risk assessment on bovine derived products (EFSA, 2005). The Working Group noted that “*with higher titres of BSE affected brain the range could extend to 300 ID₅₀/g*” and decided to take a precautionary view and to assume that the infectivity titre in brain of a clinically BSE infected bovine follows the following distribution:

Log normal distribution with

Median (50 percentile): 5 cattle oral ID₅₀/gram

Higher 99 percentile: 100 cattle oral ID₅₀ (CoID₅₀)/gram

It is considered that this distribution remains a reasonable representation of the infectivity taking into account the more recent results from the attack rate experiment and the same distribution is used in this assessment.

I.2. Development of infectivity through incubation period

In its Opinion and Report of the 16 May 2002 (SSC, 2002) the Scientific Steering Committee of the EC has provided an interpretation of the pathogenesis study to try and determine the time after exposure at which infectivity can be detected in the central nervous system and spinal cord. It highlights the problems in interpreting the data and concludes that the assumption made by the SSC in its opinion of the 12 January 2001, - i.e. "that in general, as a reasonable worst case assumption, the dorsal root ganglia and the spinal cord are considered to pose a higher risk as from the second half of the incubation period" - remains valid.

Analysis of the data from the VLA Pathogenesis experiment for the OTM review risk assessment (Comer and Huntly, 2004) resulted in an estimate of a 2 month doubling time. This would indicate that the infectivity at 50% and 70% of the incubation period is 4.5 logs and 2.5 logs less than the clinical value at the end of the incubation period. An unpublished analysis of the VLA data (Arnold, personal communication) indicates that the doubling time may in fact be slightly less than this, with a most likely value of 1.3 and a 95% range of 1.0 to 1.9 months. It is proposed that the 2 month doubling time will still be used in this study for consistency with the previous work but that a value of 1.3 will be used in the sensitivity assessment.

I.3. Infectivity in non CNS tissues

Infectivity has been found in only a limited range of tissues in an animal with clinical BSE. In the pathogenesis study a large range of tissues were tested at various stages through the incubation of the disease using mouse bioassay and subsequently a more limited range of tissues were also tested by intracerebral inoculation into calves. The only non CNS tissues shown to harbour infectivity in these experiments are the distal ileum and tonsil. The distal ileum was found to be infectious from early in the incubation period with infectivity titres only slightly less than those in the CNS. However, in the abattoir the distal ileum is removed together with the entire abdomen and there is effectively no chance for the carcass to be contaminated with distal ileum.

Infectivity was detected in tonsil 10 months post exposure, but only one of 5 calves inoculated intracerebrally became infected (Wells *et al*, 2005). It has been estimated (EFSA, 2008) that the infectivity in the tonsil tissue was less than 1 bovine i.c. ID₅₀/g or 10^{-6.5} bovine oral ID₅₀/g. There were no other positive results for tonsil at subsequent time points, but for this study it will be assumed that this low level of infectivity could persist through the incubation period.

I.4. Infectivity in the Peripheral Nervous System

There have been a number of recent reports of very low levels of infectivity found in some peripheral nervous system tissues using highly BSE sensitive mice (Buschmann & Groschup, 2005; Iwata *et al*, 2006). Buschmann & Groschup (2005) estimate that the infectivity in the sciatic nerve was about 6 logs lower than that in the brain, and Iwata *et al* (2006) showed infectivity in the femoral and lumbar nerves of naturally infected cattle estimated to be 1,000 to 1,400 fold less than in the spinal column. This range of infectivity will be combined with an estimate of the amount of PNS tissue in cattle from the VLA (personal communication, 2008).

I.5. Total Infectivity in Clinical case

The total infectivity in a clinical case of BSE is summarised in Table I.1. The weights of the various tissues are mainly taken from the LFRA (1997) report and the infectivity values are as discussed above, with the infectivity for whole brain taken to be 5 bovine oral ID₅₀/g. It can be

seen that 90% of the infectivity is associated with central and peripheral nervous system tissues, with about 10% associated with the distal ileum.

Table I.1: Infectivity in a Clinical Case of BSE (Bovine oral ID₅₀)

Tissue	Weight	Infectivity		%
		kg/animal	ID50/g	
Brain	0.5	5	2500	60.2%
Spinal cord	0.2	5	1000	24.1%
Dorsal root ganglia	0.03	5	150	3.6%
Trigeminal ganglia	0.02	5	100	2.4%
Lingual Tonsil	0.05 ¹	0.00005	0.0025	<0.01%
Distal ileum	0.8	0.5	400	9.6%
PNS	0.96 ²	0.0004	0.15	<0.01%
TOTAL	1.6		4150	
Notes:				
1. The LFRA (1997) report gives the total weight of the tonsil as 200g. 50g is an estimate of the weight of the lingual tonsil.				
2. Estimate of total PNS weight from VLA				

I.6. Significance of Exposure Estimates

The infectivity of BSE for humans is believed to be lower than in cattle due to the species barrier. The species barrier in this context is defined as the factor by which the effective infectivity in one species is reduced when given to a second species. Thus, if the cattle–human species barrier was 100, it would mean that 100 times more infective material would be required in order to have a similar probability of infecting a man compared to a bovine.

As part of the work for the review of the Over Thirty Month rule, Comer and Huntly (2004) estimated the total exposure of the UK population to BSE infectivity through food. They estimated that a total of 54 million bovine oral ID₅₀ units entered the human food chain from 1980 to 2001. However, at the time of that study the latest data from the attack rate experiment was not available and a different assumption for the infectivity of bovine tissues was used that was a factor of 10 higher. Thus to be consistent with this present study the estimate should be divided by 10 and a value of 5 million bovine oral ID₅₀ units consumed by the UK population should be used. This would indicate that the average exposure of the population (assumed to be 60 million) over the 20 year period would have been 0.004 bovine oral ID₅₀ units per person per year.

There have been a total 166 cases of vCJD in the United Kingdom (April 2008), and it now seems that the epidemic reached a peak in 2000 and there has been a subsequent decline in the numbers of vCJD cases (CJD Surveillance Unit, 14th Annual Report, 2005). Current estimates of the total size of the vCJD epidemic have reduced significantly from the high numbers thought possible a few years ago to an upper limit of 550 in a recent report (Clake & Ghani, 2004). In fact Clarke and Ghani give a best estimate of 70 future deaths, and state that *“even in the worst case scenario, when non-MM homozygous individuals are equally susceptible but have longer mean incubation period than MM homozygous individuals, the best estimate of the potential scale of the epidemic is unlikely to exceed 400 future cases.”*

An indication of the significance of the exposure estimates may then be obtained by comparing the total exposure estimate over the BSE epidemic (5 million bovine oral ID₅₀ units) with the upper limit of 550 total cases of vCJD. If the exposure is factored by 40% to allow for the proportion of methionine homozygous individuals then it is calculated that the estimated exposure per expected vCJD case is in the order of 4,000.

I.7. BSE prevalence

I.4.1 Model results

Updated estimates of the proportion of cattle that were slaughtered with BSE infection in 2007 within the last 12 months of the incubation period have been provided by the VLA for three age groups:

1. Cattle born before 1 August 1996
2. Cattle born after 1 August 1996 that are over 30 months of age
3. Cattle under 30 months of age.

The calculations were performed using the back-calculation model of Arnold and Wilesmith (2003). The culling rate for human consumption was estimated from 2004 age at slaughter data, assuming an adult population of 4.2 million and that 20% of cattle previously designated as casualty slaughter would enter the food chain. Animals over 30 months are assumed to undergo a post mortem diagnostic test which detects 99% of cattle at clinical onset, 50% of cattle 3

months before onset and <1% at >4 months before onset (see Arnold and Wilesmith, 2003). The proportion of infected animals in the last 12 months of the incubation period is estimated using an assumed age-at-onset distribution (derived from data on clinical cases 1984-1995).

Results are given in Table I.2 for both before and after BSE testing, and for three time periods: less than 3 months before onset, 4 to 6 months before onset and 7 to 12 months of onset. The last column in Table I.2 gives a weighted mean value, where the proportion with infection is weighted by the infection level for the incubation stage assuming a 2 month doubling time. It is these weighted mean values that are used in the assessment.

Table I.2 : Proportion of Cattle slaughtered with BSE Infection

a) No BSE testing

Age at slaughter	Incubation stage (months before onset)			Weighted mean
	0 – 3 months	4 – 6 months	7 – 12 months	
Born before 1 August 1996	1.58E-04	1.55E-04	3.01E-04	1.47E-04
OTM but born after 1 August 1996	1.18E-06	1.11E-06	2.08E-06	1.08E-06
Infectivity reduction (2 month doubling time)	62%	22%	5%	

b) After BSE testing

Age at slaughter	Incubation stage			Weighted mean
	0 – 3 months	4 – 6 months	7 – 12 months	
Born before 1 August 1996	9.58E-06	1.47E-04	3.01E-04	5.33E-05
OTM but born after 1 August 1996	7.13E-08	1.05E-06	2.08E-06	3.79E-07

Appendix II Assessment of Branch Probability Values in the Expert Workshop

II.1. Introduction

An Expert Workshop was held at the Defra Innovation Centre in Reading on Wednesday 16th April. The objective of the Expert Workshop was to establish values for the various branch probabilities of the SRM Controls Model that rely on expert judgement.

The workshop attendees included representatives from both the regulator (the Meat Hygiene Service) and from Industry as well as a consumer representative and representatives from the two Government Departments involved, the Food Standards Agency and Defra. The Workshop was led by Philip Comer, the DNV Project Leader and facilitated by Trevor Cooper of IBM Consulting who works with the Defra Innovation Centre.

Expert Workshop Attendees

Name	Organisation
Philip Comer	DNV (Project Leader)
Trevor Cooper	IBM (Facilitator)
Frances Moreno	MHS, AOV
Kevin Whiting	OV
Stuart Roberts	BMPA, Director
David Lindars	ABP
Steve Lomax	AIMS (OV)
Susan Knox	FoodAware
Chis Walding	FSA
Patrick Burke	Defra

II.2. Workshop Approach

The workshop was conducted as a “mini Delphi” method to elicit the branch probability values from the experts present and made use of the interactive voting facilities available at the Innovation Centre. Following a brief introduction to the SRM Controls Model and the workshop approach, the group worked systematically through the 9 event trees that make up the SRM Controls Model, with a total of 22 branch nodes considered.

Each event tree and the specific failure represented by each node was described to ensure that all participants had a common understanding. The participants were then asked to select values for the Minimum, Best Estimate and Maximum of the branch probability. This was done blind, so that the values selected by other participants are not visible until all had chosen their value. Once all the participants had “voted” the results were presented as a histogram. The results were then discussed by the group, with particular attention on the rationale behind the more extreme values chosen. The group were then given the chance to vote a second time. It is the revised Final vote values that have been used in the model. In some cases where there was good agreement, the group decided that there was no need for a second vote.

Participants were given the opportunity not to vote if they felt that they did not have knowledge about the particular issue. Susan Knox from FoodAware did not vote at all as her role in the workshop was that of observer rather than expert.

The results from the workshop are presented below for each of the Event Trees in the model. The raw results for each node are presented as a histogram of the final values chosen for each node. These show the “Minimum”, “Best Estimate” and “Maximum” values of the branch probabilities selected by the workshop experts. The resulting values for use in the model are then shown in the table for each Event Tree. In general, a single outlier vote has been disregarded. Thus for Node 1.1 in Event Tree 1a, there was a single vote for a Maximum value of 10^{-2} (1.0 E-02). This is not used and the maximum value has been set as 10^{-3} (1.0 E-03).

II.3. Event Trees 1a & 1b – Identification and Health Check in Lairage

Tree 1a & 1b Branch Probabilities

	Node Ref	Description	Min	Best Est	Max
Tree 1a		Match cattle eartags with passport information.			
Responsible		Operator			
Frequency		Every animal			
Output		Animals with checked identity			
Description of failure		Animal passes to slaughter with incorrect identification papers, may be animal born before August 1996 (BB96) or other which should not enter normal slaughter process.			
Likelihood of failure	1.1	ID not checked in lairage	1×10^{-6}	1×10^{-5}	1×10^{-3}
	1.2	BB96 animal not identified	1×10^{-5}	1×10^{-3}	1×10^{-2}
Tree 1b		Animal health checked by Official Veterinarian			
Responsible		MHS			
Frequency		Every animal, although may be done in groups			
Output		Healthy animals to slaughter			
Description of failure		High risk animals slaughtered and enter food supply			
Likelihood of failure	1.3	Health check not carried out effectively	1×10^{-6}	1×10^{-5}	1×10^{-2}
	1.4	High risk animal not identified	1×10^{-5}	1×10^{-4}	1×10^{-3}

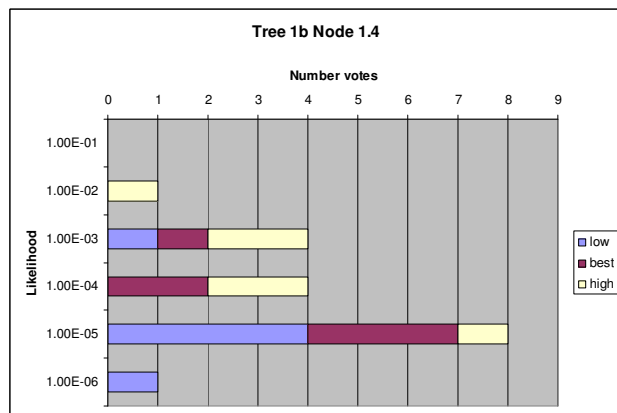
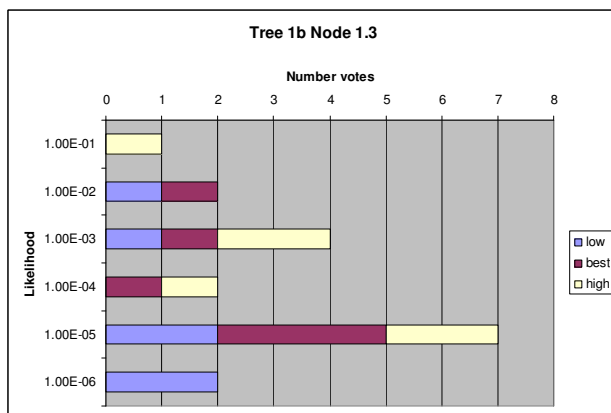
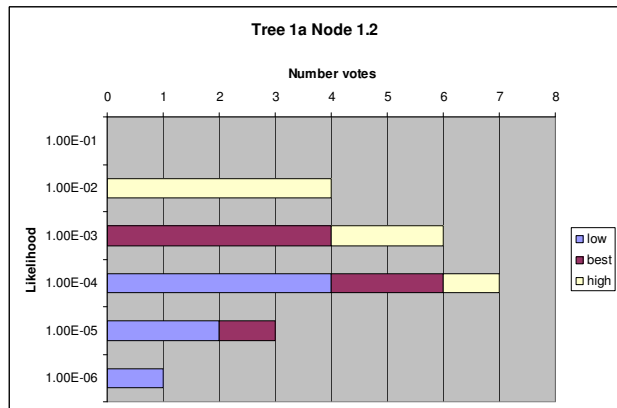
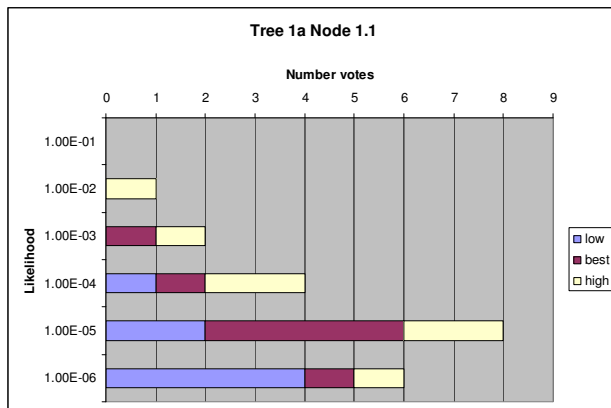

II.4. Event Tree 2: Post Mortem Inspection

	Node Ref	Description	Min	Best Est	Max
Tree 2		Post-mortem check - correct animal			
Responsible		MHS			
Frequency		Every animal			
Output		Animals with identity verified passing to processing			
Definition of failure		Animal passes to processing with incorrect identification papers, may be BB96 animal or other which should not enter normal slaughter process.			
Description of failure		Proportion of BB96 animals not identified from document check			
Likelihood of failure	2.1	ID/age not checked PM?	1×10^{-5}	1×10^{-4}	1×10^{-3}
	2.2	BB96 animal not identified	1×10^{-6}	3×10^{-5}	1×10^{-3}

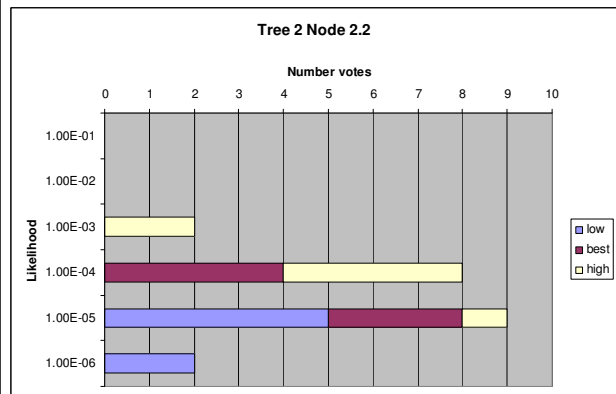
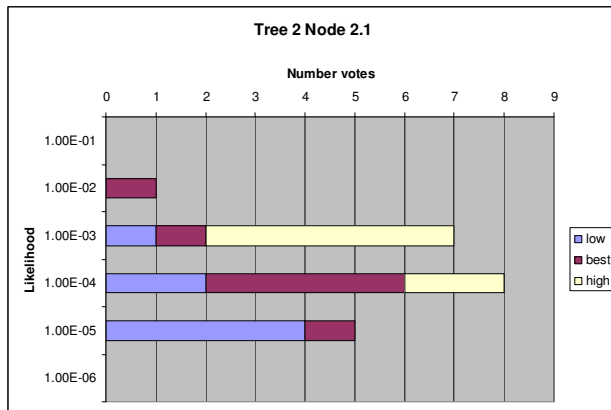

II.5. Event Tree 3: BSE Testing

	Node Ref	Description	Min	Best Est	Max
Tree 3		Brain stem sample taken and sent to laboratory			
Responsible		Operator			
Frequency		Every animal			
Output		Correctly labelled sample matched to carcass sent for analysis			
Definition of failure		Sample not matched to carcass or wrong sample			
Description of failure		Incorrect samples sent to laboratory			
Likelihood of failure	3.1	Sample not taken	1×10^{-6}	1×10^{-5}	1×10^{-4}
	3.2	Sample substitution	1×10^{-6}	1×10^{-5}	1×10^{-4}
	3.3	Sample wrongly labelled	1×10^{-5}	1×10^{-4}	1×10^{-3}

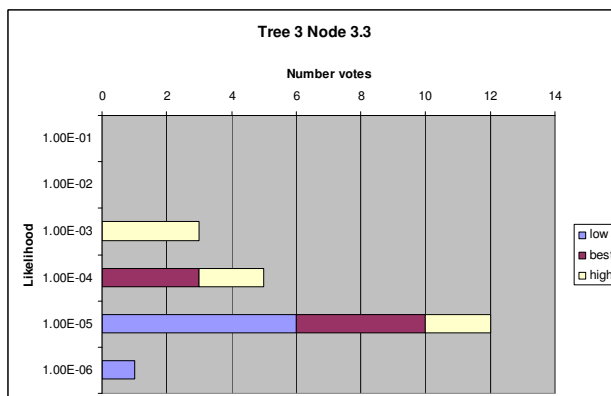
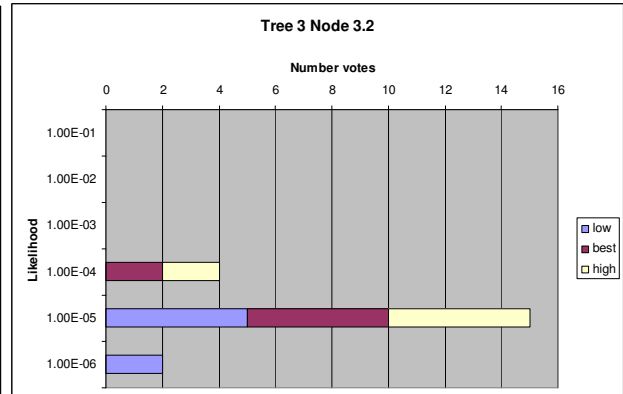
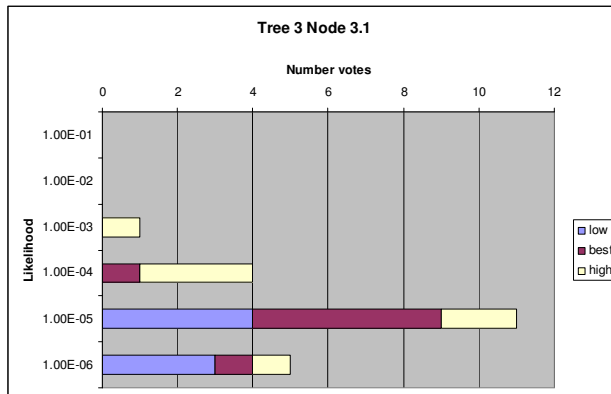

II.6. Event Tree 4a & 4b: Harvesting Head Meat and Tongue

	Node Ref	Description	Min	Best Est	Max
Proportion of tongues harvested	4.1	It has been assumed that all tongues from UTM animals are harvested. Proportion for OTM slaughter			
Step		Tongue removed and trimmed correctly			
Responsible		Operator			
Frequency		Every animal			
Output		Correctly trimmed tongue with no SRM to food supply			
Definition of failure		Tongue with part of tonsil attached			
Likelihood of failure	4.2	Proportion of tongues incorrectly trimmed	1×10^{-5}	2×10^{-5}	1×10^{-3}
Step		Tongue inspected by MHS			
Responsible		MHS			
Frequency		Every tongue			
Output		Inspected tongue with no SRM to food supply			
Definition of failure		Inspection fails to identify incorrectly trimmed tongue			
Likelihood of failure	4.3	Proportion of incorrectly trimmed tongues passed as fit to eat	1×10^{-5}	5×10^{-4}	1×10^{-2}
Head meat removal					
Step		Head meat harvested			
Responsible		Operator			
Frequency					
Output		Head meat into food supply			
Definition of event		Proportion of heads from which meat is harvested			
Likelihood of event	4.4				
Step		Head correctly removed, placed in SRM bin for disposal and stained			
Responsible		Operator, checked by MHS			
Frequency		Every animal			
Output		Heads stained as SRM ready for disposal			
Likelihood of failure	4.5	Head not placed in SRM bin.	1×10^{-6}	1×10^{-5}	1×10^{-4}

A survey of abattoirs is being carried out to determine values for Nodes 4.1 and 4.4.

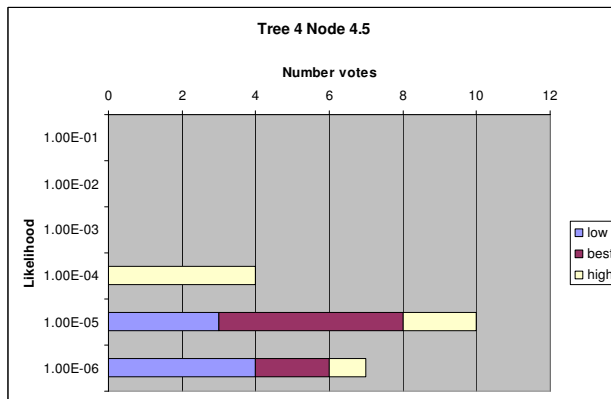
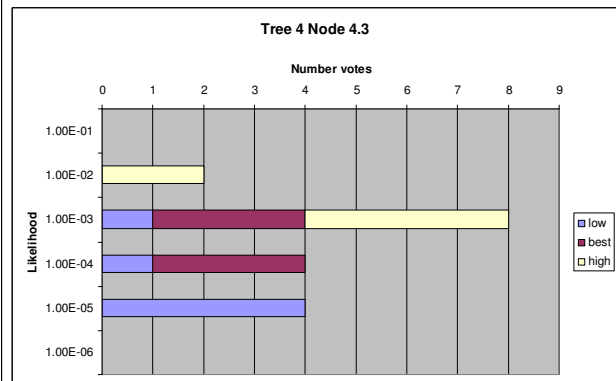
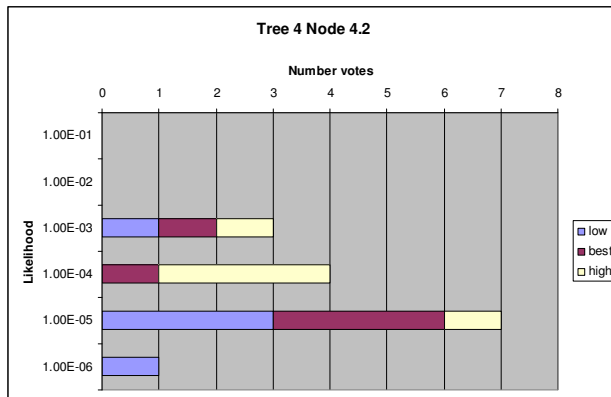

II.7. Event Tree 5: Spinal Cord Removal and Final SRM Inspection

	Node Ref	Description	Min	Best Est	Max
Step		Spinal cord correctly removed			
Responsible		Operator			
Frequency		Every animal			
Output		Carcass with no spinal cord			
Definition of failure		Parts of spinal cord left on carcass			
Likelihood of failure	5.1	Spinal cord not completely removed	1×10^{-5}	3×10^{-5}	1×10^{-4}
Step		Inspection			
Responsible		MHS			
Frequency		Every animal			
Output		Inspected carcass free of SRM			
Definition of failure		Residual SRM not identified at inspection			
Likelihood of failure	5.2	Residual SRM not identified at inspection	1×10^{-6}	1×10^{-5}	1×10^{-4}

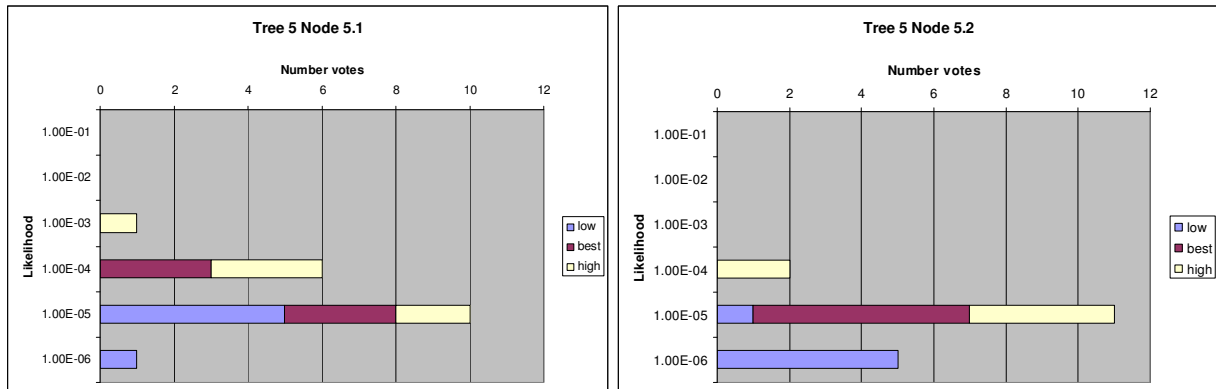

II.8. Event Tree 6: Test Results and Carcass Dispatch

	Node Ref	Description	Min	Best Est	Max
Step		BSE test results received at abattoir			
Responsible		Operator			
Frequency		Every animal			
Output		Test results linked to each animal slaughtered			
Definition of failure		Incorrect carcass removed following no test or positive result			
Outcomes	6.1	One or more result is a "No Test"			
	6.2	BSE positive result received			
Step		Carcases released from MHS control and removed if necessary			
Responsible		Operator			
Frequency		Every animal			
Output		Carcases released from MHS control and approved for human consumption			
Definition of failure		Incorrect carcass removed following no test or positive result			
Likelihood of failure	6.3	No Test carcass not identified and removed	1x10 ⁻⁶	3x10 ⁻⁶	1x10 ⁻⁵
	6.4	BSE positive and 1B2A not identified and removed	1x10 ⁻⁶	3x10 ⁻⁶	1x10 ⁻⁵

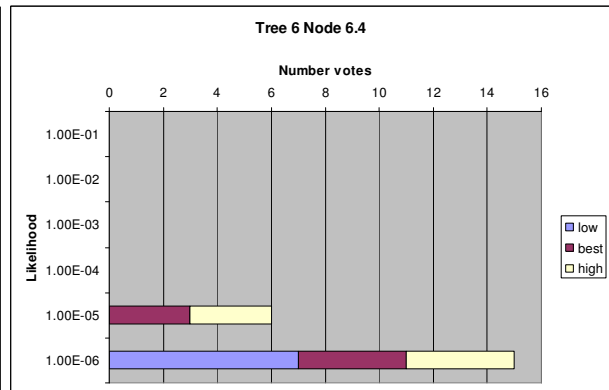
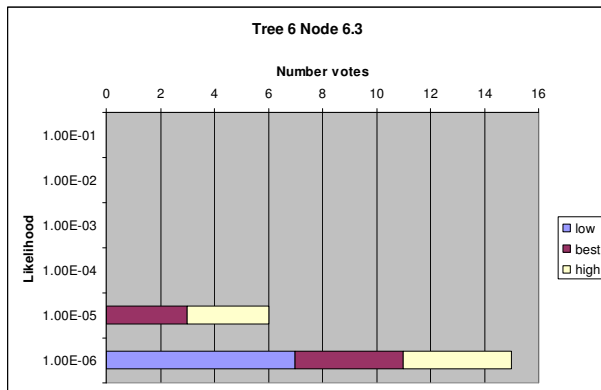

II.9. Event Tree 7: OTM Cutting Plant

		Description	Min	Best Est	Max
Process description		VC removed under MHS supervision and disposed of as SRM			
Legislative requirement		TSE Regulations			
Number of animals entering stage		Total number of animals entering OTM slaughter process per year			
Step 1		OTM Carcase sent to approved cutting plant			
Responsible		Operator (supervised by MHS)			
Frequency		Every carcase			
Output		Animals with checked identity			
Description of failure		OTM carcase misidentified as UTM			
Likelihood of failure	7.1	OTM carcase processed as UTM	1×10^{-6}	3×10^{-6}	1×10^{-5}
	7.2	OTM meat sold on bone			
Step 2		Carcase identified as OTM			
Responsible		Operator			
Frequency		Every animal			
Output		Carcase processed correctly as OTM			
Description of failure		Carcase processed with UTM material so VC not disposed as SRM			
Likelihood of failure	7.3	Carcase processed as UTM	1×10^{-6}	1×10^{-5}	1×10^{-5}
Step 3		VC removed correctly			
Responsible		Operator			
Frequency		Every animal			
Output		VC and associated DRG removed			
Description of failure		Not all DRG removed with VC			
Likelihood of failure	7.4	Excess DRG left in meat			
Step 4		VC correctly disposed as SRM			
Responsible		Operator			
Frequency		Every animal			
Output		All SRM stained and disposed as SRM			
Description of failure		VC not disposed as SRM			
Likelihood of failure	7.5	VC not disposed as SRM	1×10^{-6}	1×10^{-5}	1×10^{-4}
	7.6	VC used in human food	1×10^{-6}	1×10^{-6}	1×10^{-5}

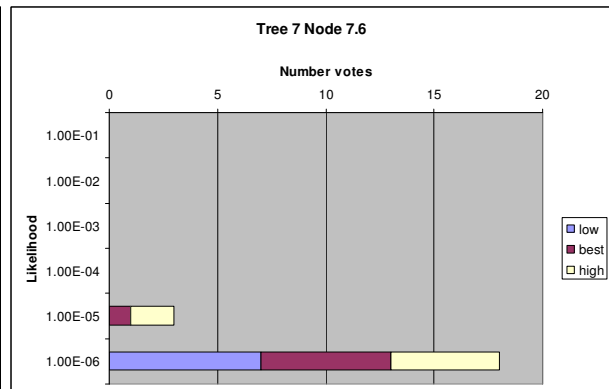
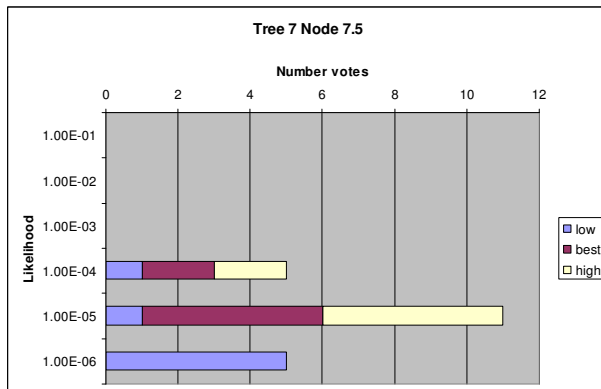
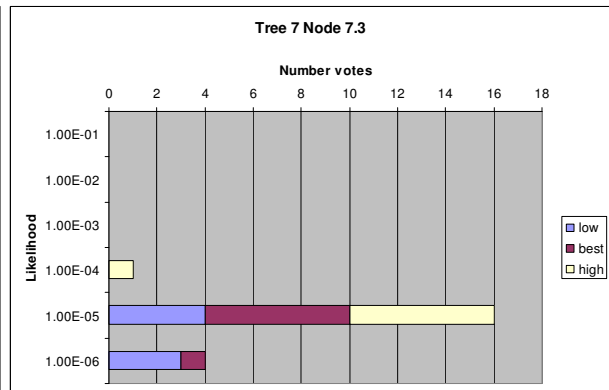
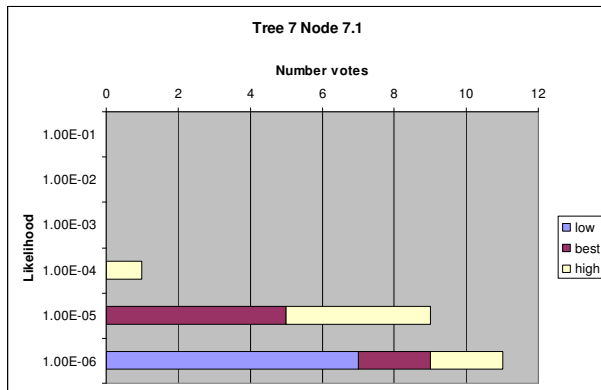

DNV Consulting:

is a different kind of consulting firm, offering advanced cross-disciplinary competence within management and technology. Our consulting approach reflects the new risk agenda in high-risk and capital-intensive industries. We have a firm base in DNV's strong technological competencies, international experience and unique independence as a foundation. Our consultants serve international clients from locations in Norway, UK, Germany, Benelux and the USA.

DNV CONSULTING
Veritasveien 1
N-1322 Hovik
Norway
Phone: +47 67 57 99 00

DNV CONSULTING
Johan Berentsenvei
109-111
N-5020 Bergen
Norway
Phone: +47 55 94 36 00

DNV CONSULTING
Bjergstedveien 1
N-4002 Stavanger
Norway
Phone: +47 51 50 60 00

DNV CONSULTING
Ingvald Ystgaardsvei 15
N-7496 Trondheim
Norway
Phone: +47 73 90 3500

DNV CONSULTING
Businesspark
Essen - Nord
Schnieringshof 14
45329 Essen
Germany
Phone: +49 201 7296 412

DNV CONSULTING
Duboisstraat 39 – Bus 1
B-2060 Antwerp
Belgium
Phone: +32 (0) 3 206 65 40

DNV CONSULTING
Palace House
3 Cathedral Street
London SE1 9DE
United Kingdom
Phone: +44 20 7357 6080

DNV CONSULTING
Highbank House
Exchange Street
Stockport
Cheshire SK3 0ET
United Kingdom
Phone: +44 161 477 3818

DNV CONSULTING
Cromarty House
67-72 Regent Quay
Aberdeen AB11 5AR
United Kingdom
Phone: +44 1224 335000

DNV CONSULTING
16340 Park Ten Place
Suite 100
Houston, TX 77084
USA
Phone: +1 281 721 6600

a different approach for a new reality:

DNV CONSULTING



MANAGING RISK